

LEVEL	FACE WIDTH	PLATFORM
20000	2000	
17500	2000	
15000	2000	Working Platform
12500	2000	Working Platform
10000	2000	
7500	2250	
5000	2500	
2500	2750	
0000	3000	

LEG JOINT NAME	LEG LENGTH	LEGS SIZE	PANEL NO	LENGTH(METER)	DIAGONALS	PANEL TOP- HORIZONTALS	PANEL MID- HORIZONTALS	PLAN BRACING	SEC. BRACING
A	2500	65x65x6	1	2.5	50x50x4	50x50x4	45x45x04	45x45x04	
B	2500	75x75x6	2	2.5	55x5	50x50x4	45x45x04	45x45x04	
C	2500	100x100x10	3	2.5	60x60x5	50x50x4	50x50x4	50x50x4	
D	2503	120x120x10	4	2.5	50x5	50x5	50x50x4	50x50x4	
E	2503		5	2.5	50x50x5		50x50x4	50x50x4	
	2503		6	2.5					
	2503		7	2.5					
	2503		8	2.5					

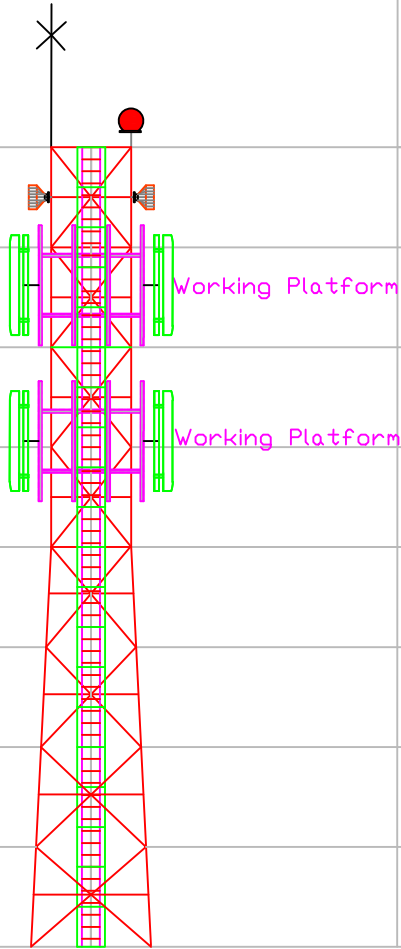

PLAN VIEWS

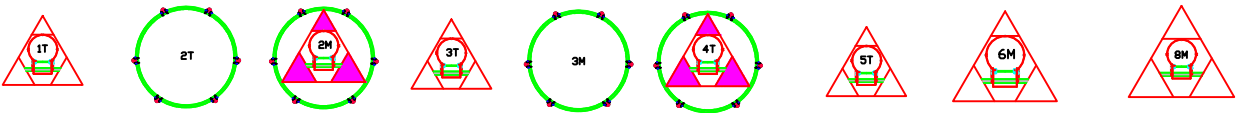

1) Remote Radio Head- 6+3nos (Total Weight 240kgs.) 2) Sectoral Antennas - 6+3nos (Total Weight 222kgs.) 3) Microwave Antennas (0.9m)-2nos (Total Weight 50kgs.) 4) Microwave Antennas (1.2m)-2nos (Total Weight 60kgs.) 5) Antennas Mounting Structure (Total Weight 270kgs.)	TITLE	20 METER TOWER	Wind Speed	180 KMPH	Design	TIA/EIA-222 G
	SUB. TITLE	TRIANGULAR ANGULAR TOWER	Deflection	< 1.0 Degree	Rev:	
	Drawing	BT - 2024 Project	Loading	842 kgs.	Drawn Date	08-12-2023
	BHUTAN TELECOM LTD.			Tower Weight 3550 kgs.		

NOTES

- ALL DIMENSIONS ARE IN MM UNLESS NOTED OTHERWISE.
- USE M20 GRADE CONCRETE AND F8 500 GRADE FOR STEEL.
- CLEAR COVER TO MAIN REINFORCEMENT- (a) 25MM FOR BEAMS (c) 50MM FOR FOUNDATION (b) 40MM FOR COLUMNS
- PRIOR TO AND DURING CONCRETING ALL BOLTS SHALL BE SECURELY HELD IN POSITION BY USE OF TEMPLATE.
- BEFORE COMMENCEMENT OF CONSTRUCTION USING THIS DESIGN, CLIENT/CONTRACTOR SHALL CARRY OUT DETAILED SOIL INVESTIGATION OF EVERY SITE.
- THIS FOUNDATION DESIGN SHALL NOT BE USED IN CASE HIGHLY SOIL ARE FOUND AT ANY DEPTH DURING SOIL INVESTIGATION.
- CONCRETE SHALL BE MECHANICALLY MIXED & VIBRATED.
- SPACING OF BARS SHALL NOT BE MORE THAN 50% AT ANY LOCATION.
- PROPER CURING OF CONCRETE SHALL BE DONE.
- BENDING OF BARS SHALL BE AS PER IS:2502.
- ANY DISCREPANCY SHOULD BE BROUGHT TO THE CONSULTANT'S ATTENTION.

GENERAL DETAILS

S.No	DESCRIPTION	DETAILS
1	SOIL BEARING CAPACITY	10.00 T/SQM
2	DRY DENSITY OF SOIL	1.8 T/SQM
3	ANGLE OF REPOSE	30.00 DEGREE

BILL OF MATERIALS

ITEM	UNIT	TOTAL
EXCAVATION	CUM	43.6
PCC-(1:4:8)	CUM	1.95
RCC-M20	CUM	7.34
STEEL-F8500	KG	680

CHAIRS SHALL BE PROVIDED WHEREVER REQUIRED

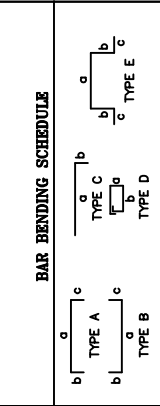

REVISION NOTES

REV. NO.	DESCRIPTION	DATE	SIGN.
DRAWN	CHECKED	APPROVED	DATE
Bhutan Telecom	Bhutan Telecom	Bhutan Telecom	14-12-2023

CLIENT: BHUTAN TELECOM LTD.
 DESIGN BY: BHUTAN TELECOM LTD.
 PROJECT: GENERIC ISOLATED FOUNDATION DESIGN
 TITLE: FOUNDATION DETAILS FOR 20M HIGH TRIANGULAR TOWER
 SBC : 10 T/SQM
 DRAWING No. SH. NO. REV.
 BT-2024 Project

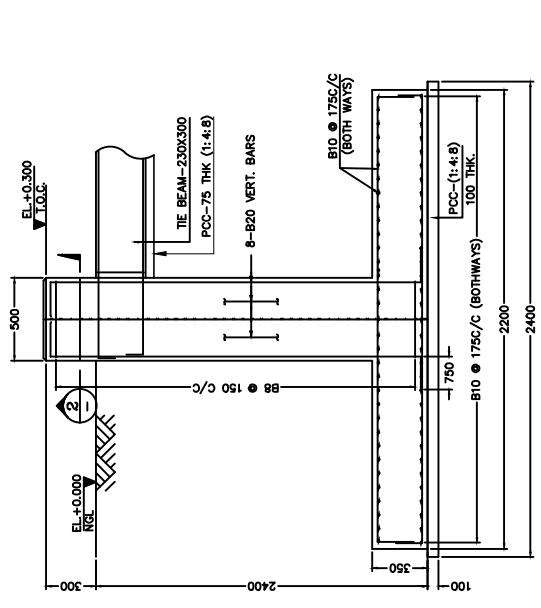

SECTION 1

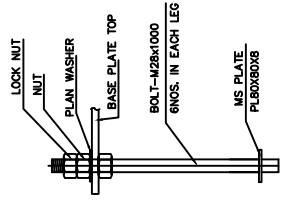

ANCHOR BOLT

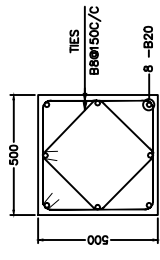

SECTION 2
COLUMN 500X500

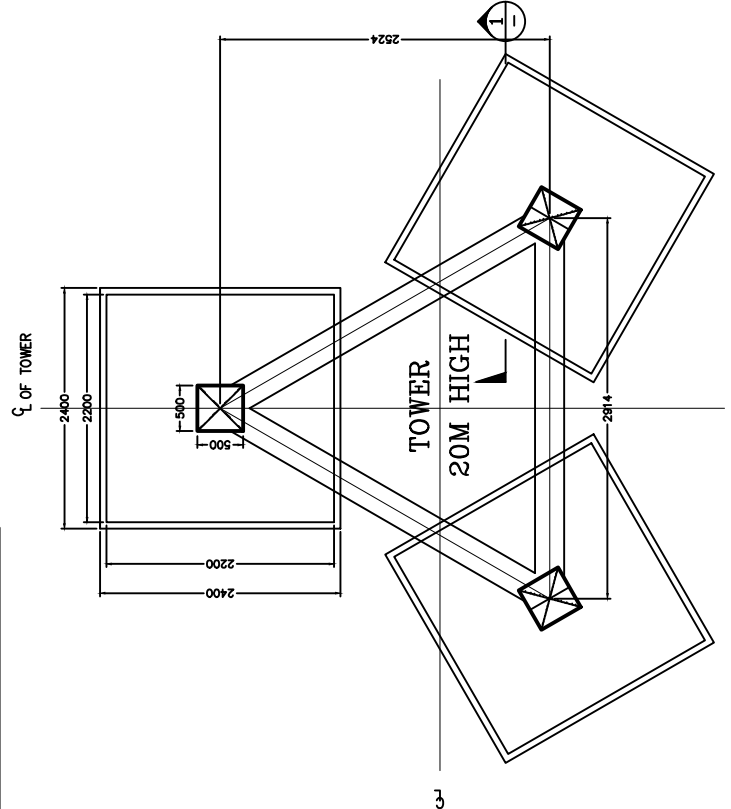

FOUNDATION KEY PLAN

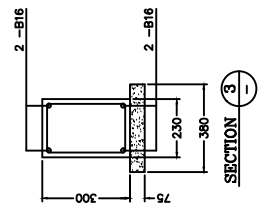

SECTION 3

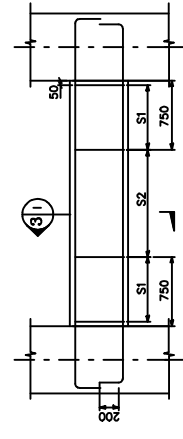

TIE BEAM (TYP DETAILS)

STIRRUP DETAILS
 S1: -2 LEGGED Y8 @ 100 C/C
 S2: -2 LEGGED Y8 @ 200 C/C

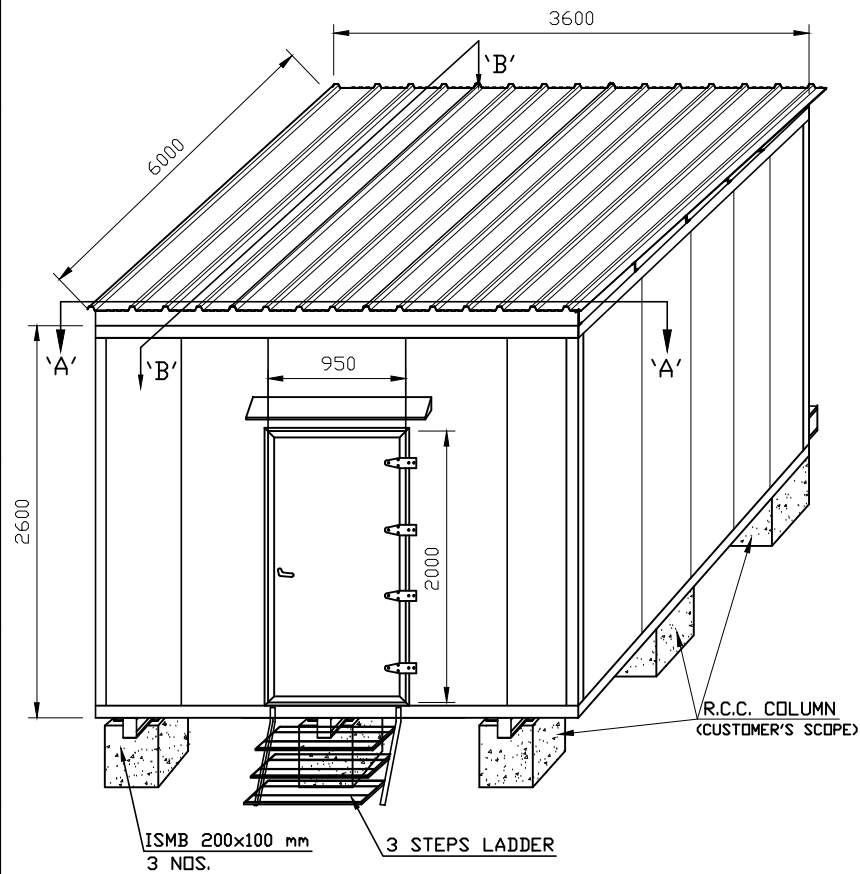

PERSPECTIVE VIEW

ALL DIMENSIONS ARE IN mm

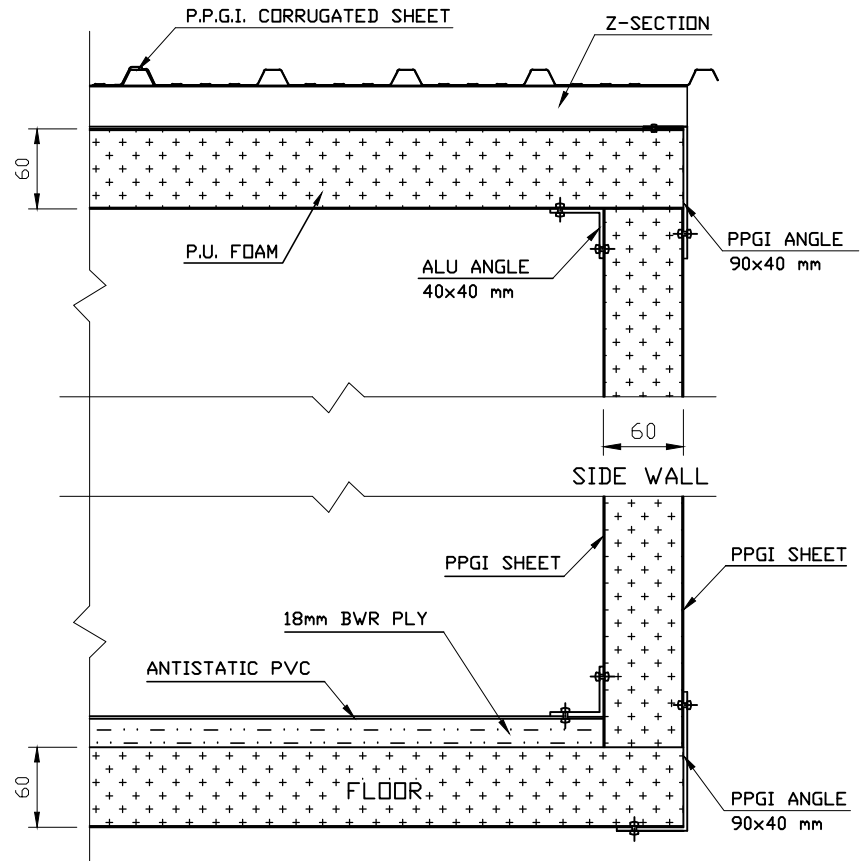

SECTION 'A-A'
SCALE 10:1

DIMENSION :	
EXT :	6000x3600x2600 mm
INT :	5880x3480x2480 mm
PANEL THICKNESS :	60 mm
SKIN :	0.6mm P.C.S. AWT (OUTER)
	0.6mm P.C.S. AWT (INNFR)

BHUTAN TELECOM LIMITED

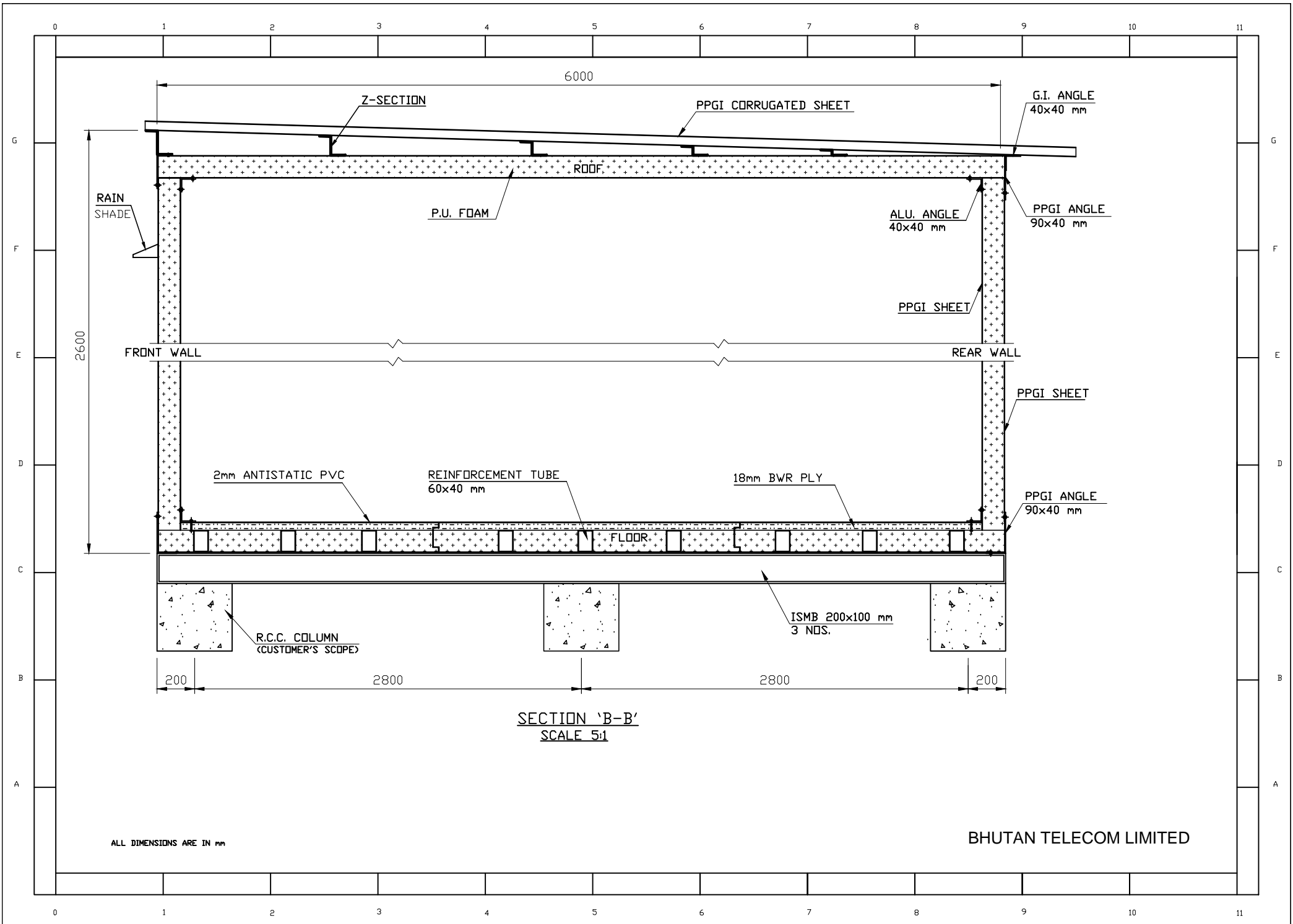

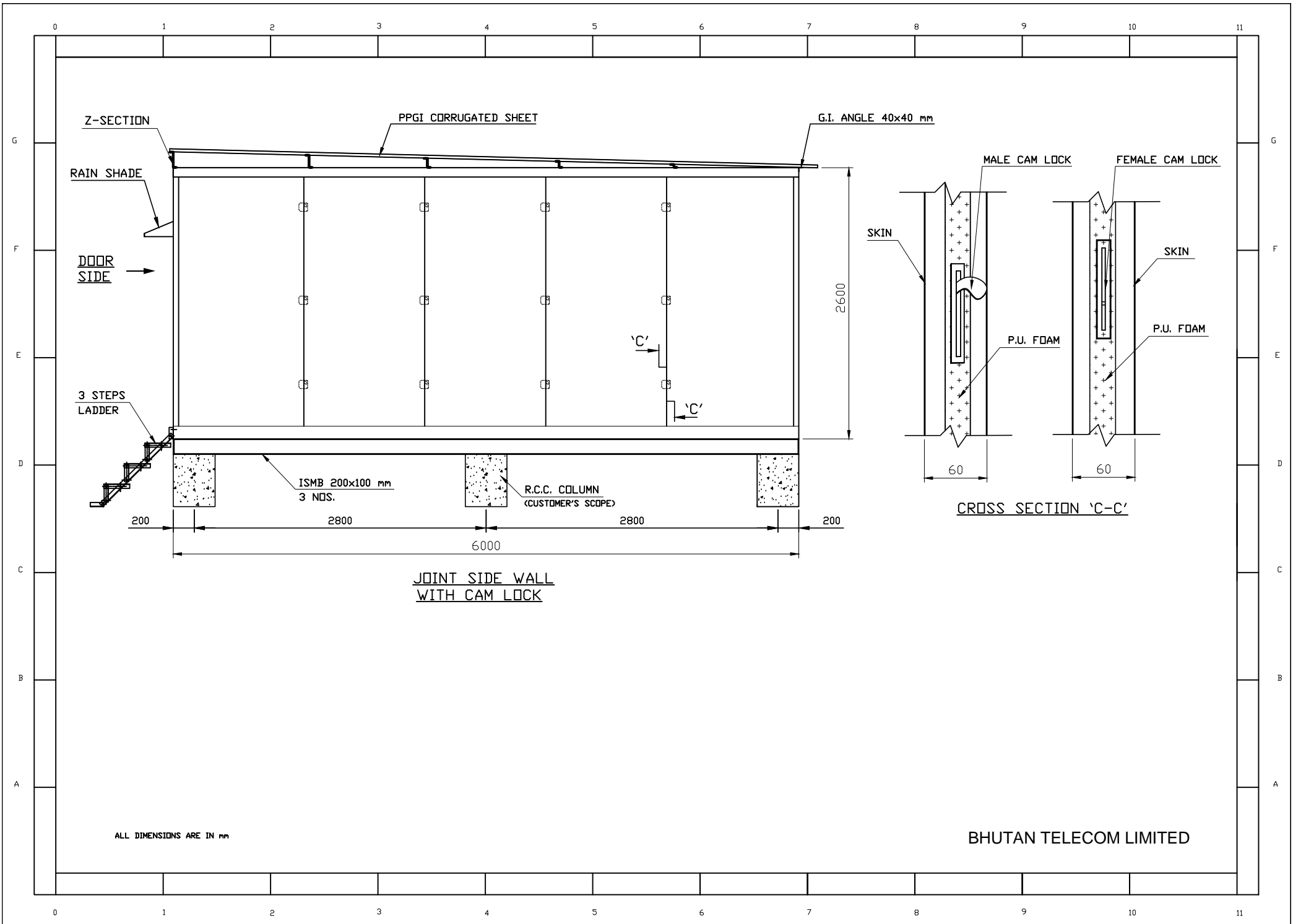

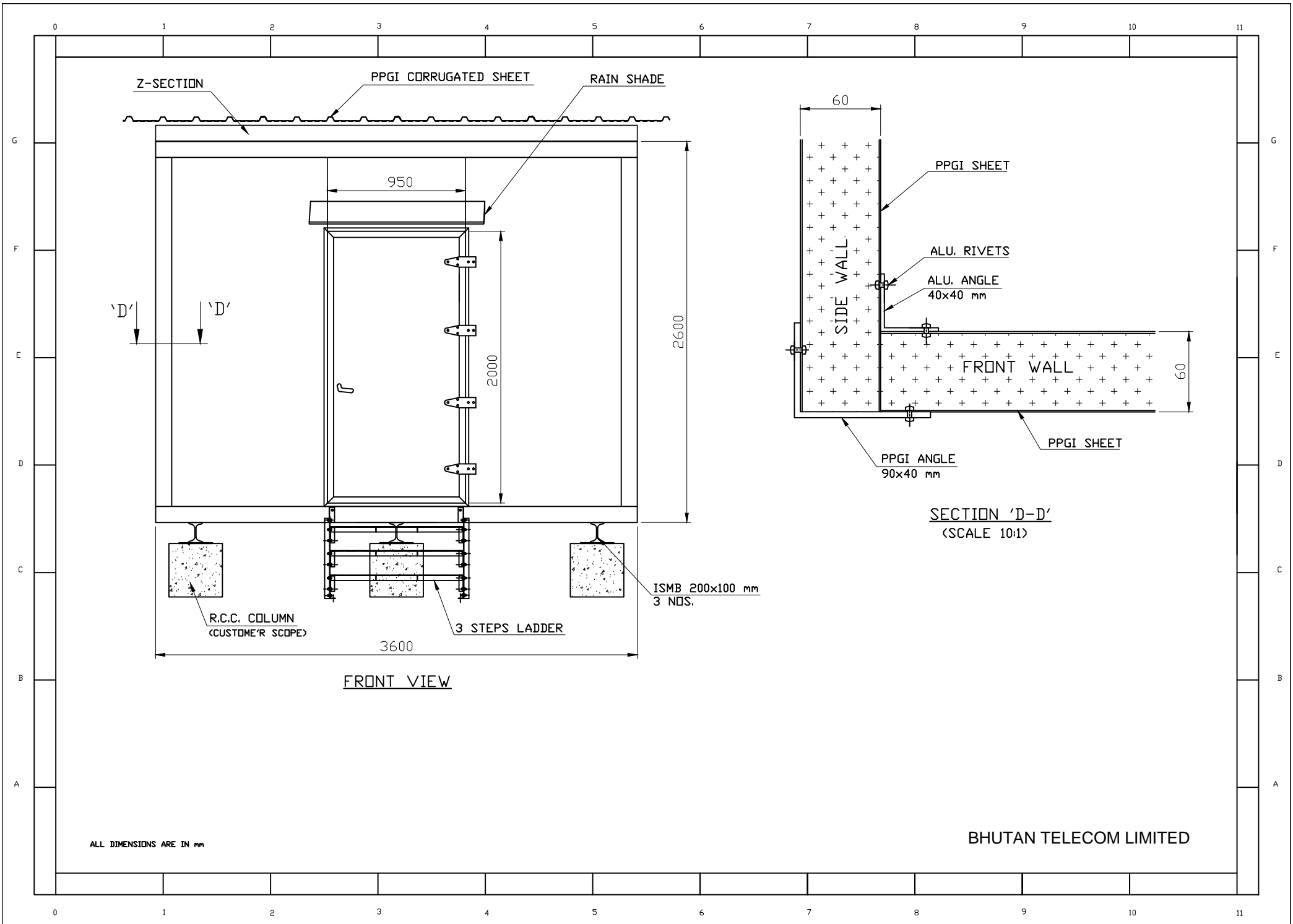

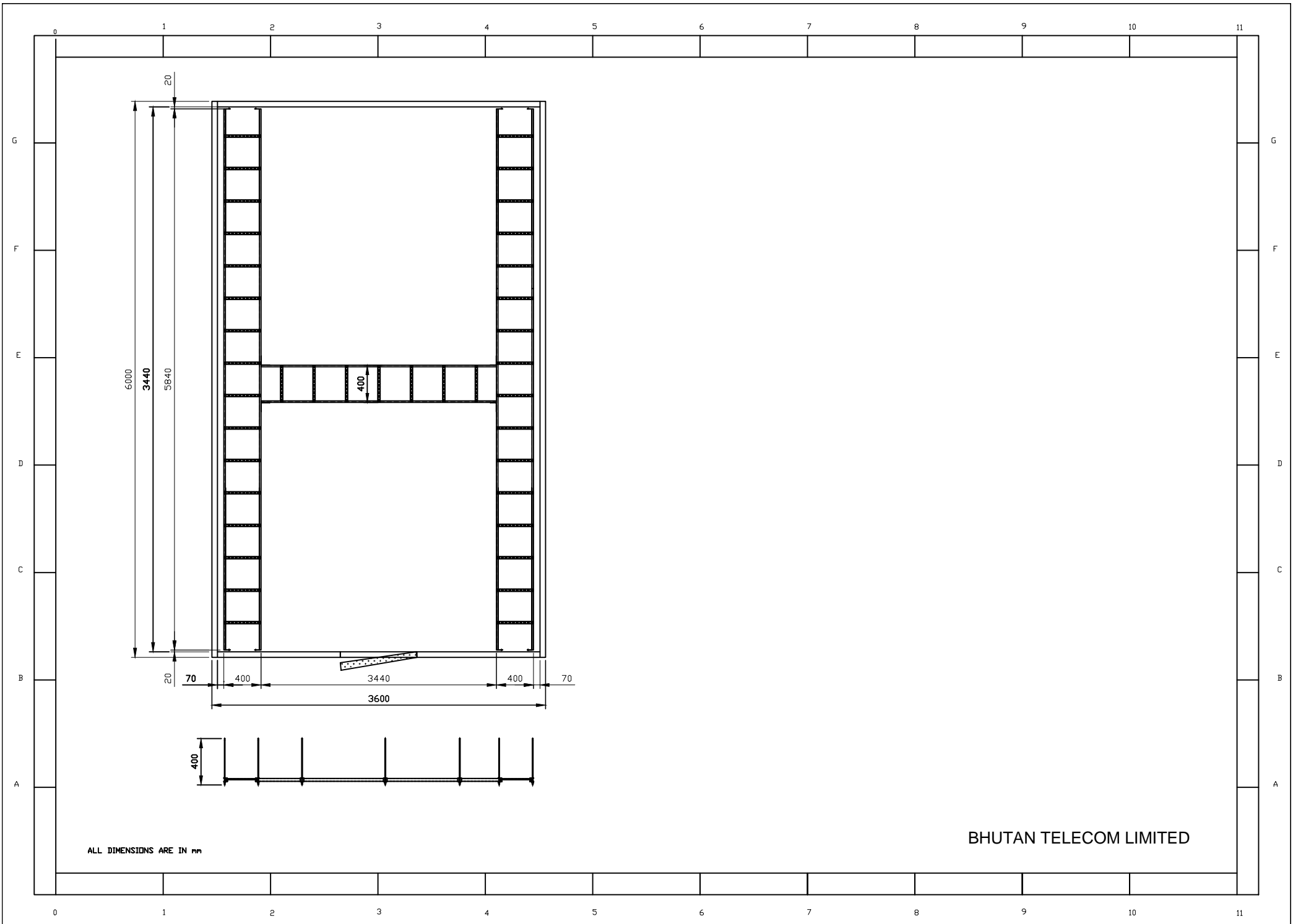

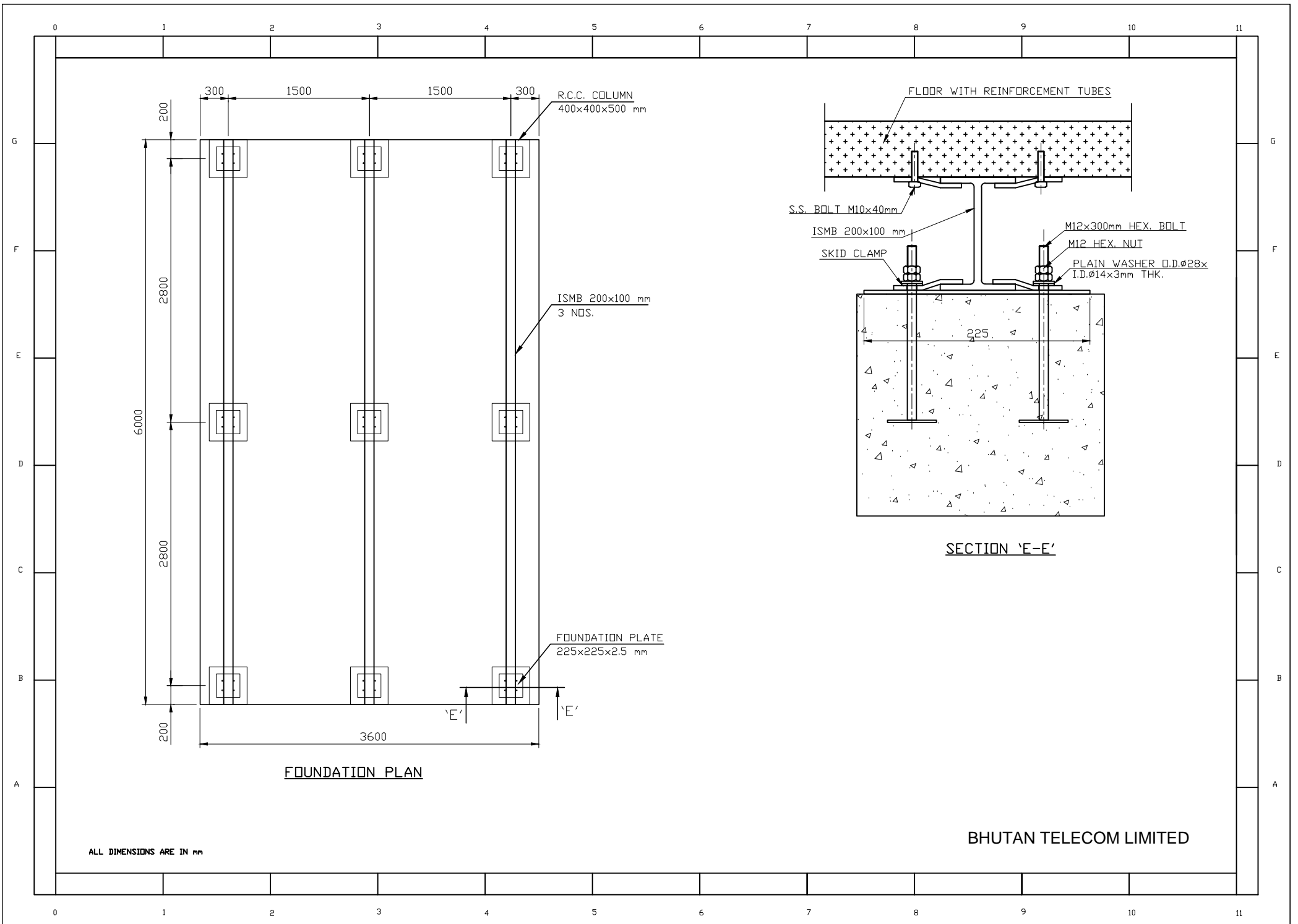

Anchor Bolt Dimensions:

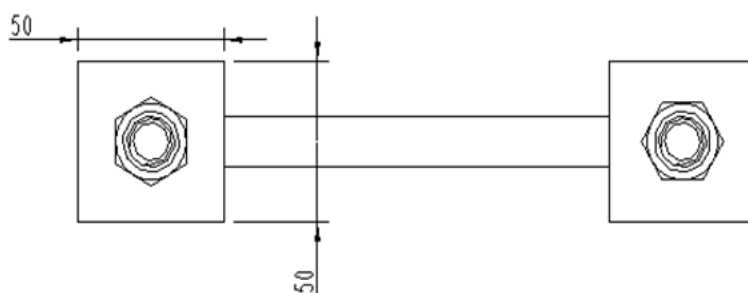
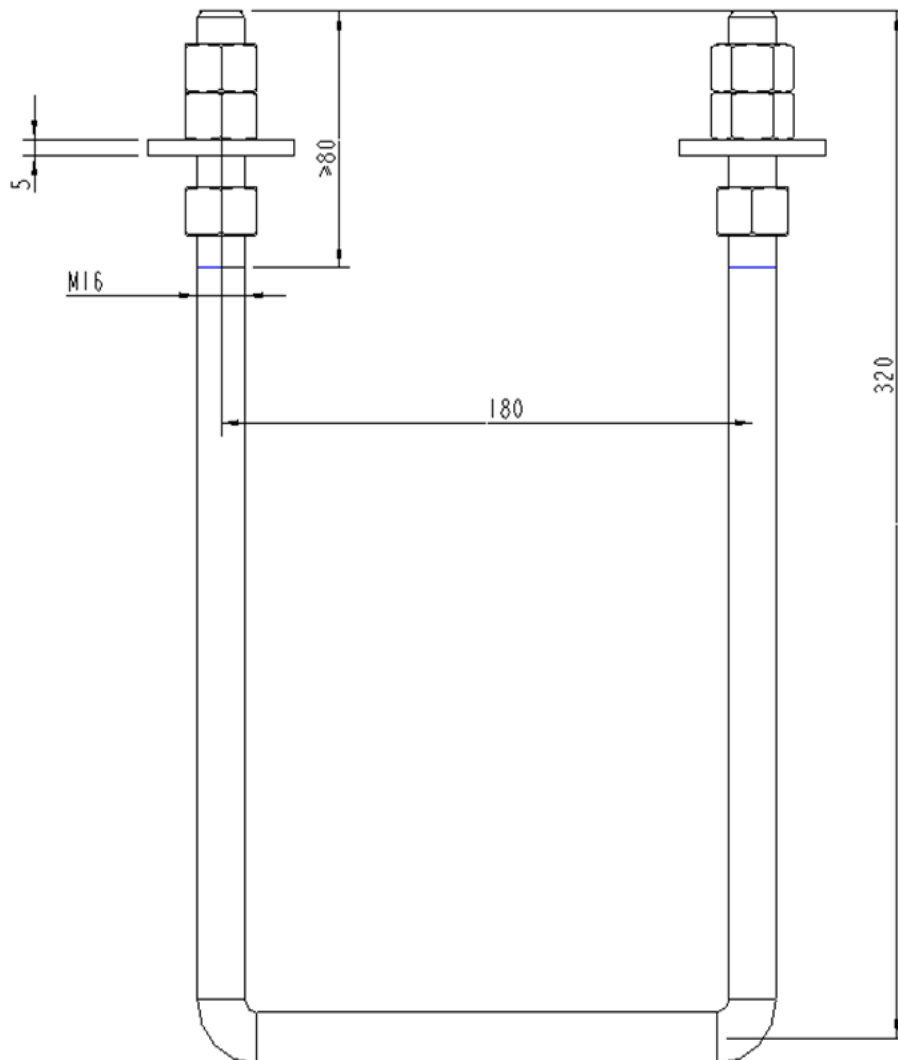

GENERAL DESCRIPTION

SCENE:

The basic wind speed of the solar bracket is related to the elevation angle of the photovoltaic panel. The basic wind speed for the elevation angle of 15, 25, 35, and 45 degrees is 40, 40, 35, and 31 m/s (3s time interval). The soil bearing capacity at the bottom of foundation should not be less than 100kPa. The support and foundation can be placed in flat terrain where the ground surface roughness category is C in ASCE 7-05 (B in GB50009-2001). In some particular scene, such as island and mountain peak, site designer should recheck the foundation design and modify the drawing.

FOUNDATION SELECTION PRINCIPLE:

1. Selection of foundation grade shall be decided by bracket height, angle.

NOTICE:

1. Wind speed is 3 second gust;
2. If site basic wind velocity exceed the design basic wind speed, or soil bearing capacity at the bottom of foundation is less than 100kPa (most is quicksand or swampland), foundation drawing should be modified. HQ GTS or R&D can be contacted.

说明

支架及基础应用场景:

该太阳能支架设计的基本风速与光伏板仰角有关，仰角为15、25、35、45度的基本风速为40、40、35、31m/s (3S时距)。按照光伏支架高度的不同分为：低支架基础和高支架基础。所有基础所在位置的地基承载力不小于100kPa。设计适用于美标C类(中标B类)地面粗糙度的平坦地区或稍有起伏地区，对于海岛或山峰等特殊地形的应用，需要站点设计人员根据实际情况对基础重新验算，并做相应的变形设计。

基础选型的一般原则:

1. 根据支架高度、角度的不同选择基础;

注:

1. 风速为3s时距;
2. 若站点基本风速高于基本风速，或者地基承载力低于100kPa(大部分为流沙或沼泽地区)，基础需重新设计。可以联系配套服务或机关研发人员。

客户:

签名: _____

分包商:



签名: _____

NOTES:

Copyright Huawei Technologies Co.,Ltd.2008. All right reserved.

No part of this document may be reproduced or transmitted in any form or by any means without prior written consent of Huawei Technologies Co.,Ltd.

项目:

Project:

备注:

Remark:

图名:

Drawing title:

备注: Sharp A Bracket 3.0 Foundation (High solar bracket)

Remark: A型支架3.0基础(高支架)

编码: Part-No:

版本: Version:

比例: Scale:

图号: NO.:

结构编号:

设计: Designed:

检查: Checked:

审核: Verified:

批准: Approved:

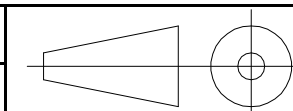

6X540W光伏组件轮廓线
Solar panel Contour(6X540W)

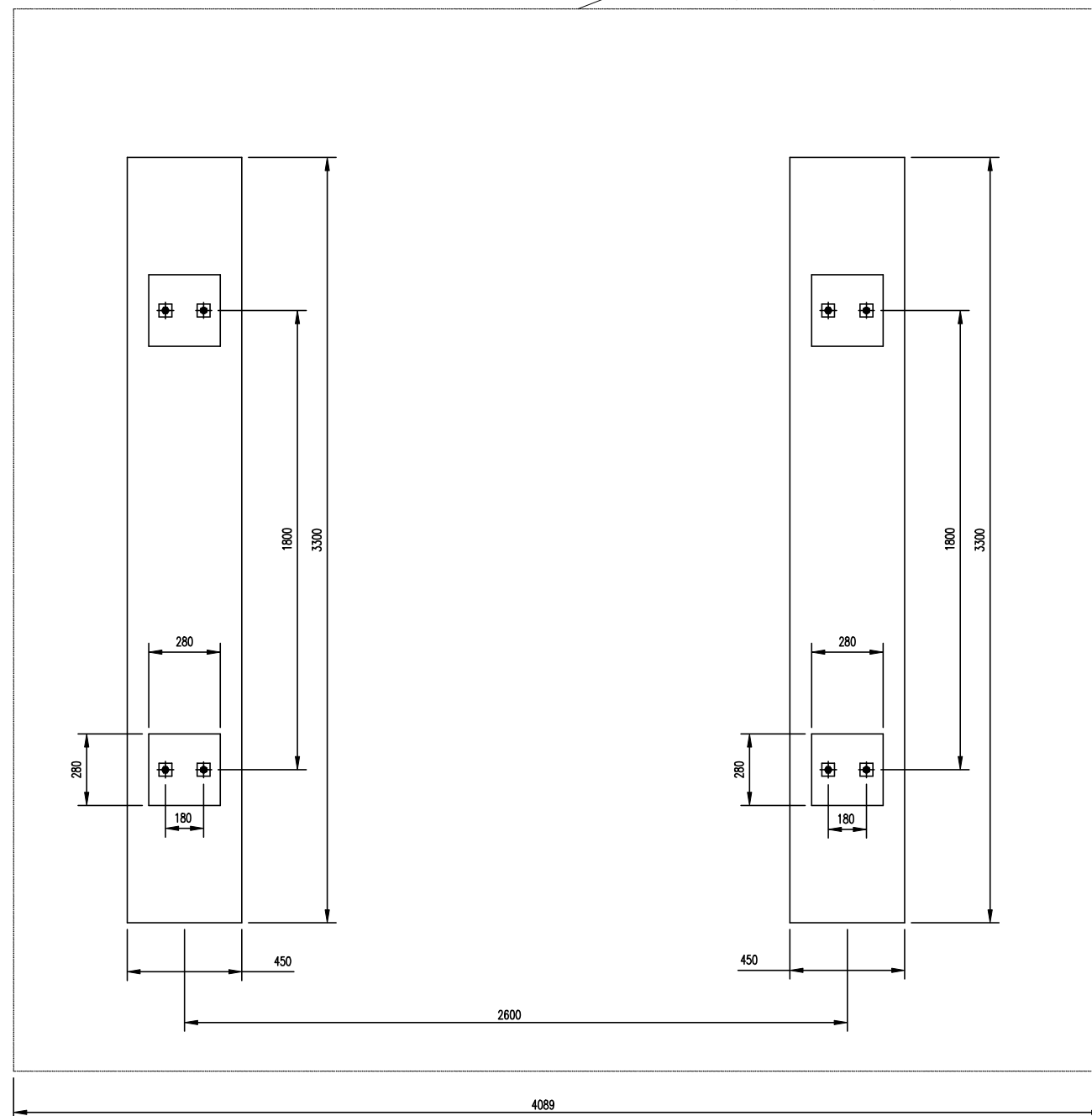

基础平面图 Foundation Plan

客户:

签名: _____

分包商:



签名: _____

NOTES:

Copyright Huawei Technologies Co.,Ltd.2008.
All right reserved.
No part of this document may be reproduced or transmitted in any form or by any means without prior written consent of Huawei Technologies Co.,Ltd.

项目:

Project:

备注:

Remark:

图名:

Drawing title:

备注: Sharp A Bracket 3.0 Foundation (High solar bracket)

Remark: A型支架3.0基础(高支架)

编码:Part-No:

版本:Version:

比例:Scale:

图号:NO.:

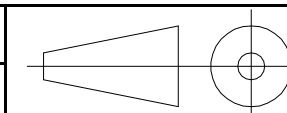

结构编号:

设计:Designed:

检查:Checked:

审核:Verified:

批准:Approved:

单条基础钢筋表 Steel Bar List of Each Foundation

编号 No.	直径 Dia. d(mm)	间距 Spacing (mm)	A (mm)	B (mm)	C (mm)	长度 Length (mm)	数量 Quantity	总长 Total Length (m)	单位重量 Weight (Kg/m)	总重 Total Weight (Kg)
R01	10	175	50	3200	50	3300	3	9.9	0.62	19.53
R02	10	198	50	350	50	450	17	7.7	0.62	
R03	10	190	50	800	50	900	8	7.2	0.62	
R04	10	/	210	210	70	560	12	6.7	0.62	

单条基础混凝土用量和开挖 Concrete and Excavation List of Each Foundation

基础混凝土 Concrete (m ³)	垫层混凝土 Concrete Cushion (m ³)	土方开挖 Excavation (m ³)	土方回填 Backfill (m ³)
0.407	0.094	1.59	1.1

钢筋外形图 Steel bar shape

编号 No.	形状 Shape	长度 Length
R01	A-B-C	L=A+B+C
R02	A-B-C	L=A+B+C
R03	A-B-C	L=A+B+C
R04	A-B	L=2(A+B+C)

客户: _____

签名: _____

分包商: _____



签名: _____

NOTES:

Copyright Huawei Technologies Co.,Ltd.2008. All right reserved. No part of this document may be reproduced or transmitted in any form or by any means without prior written consent of Huawei Technologies Co.,Ltd.

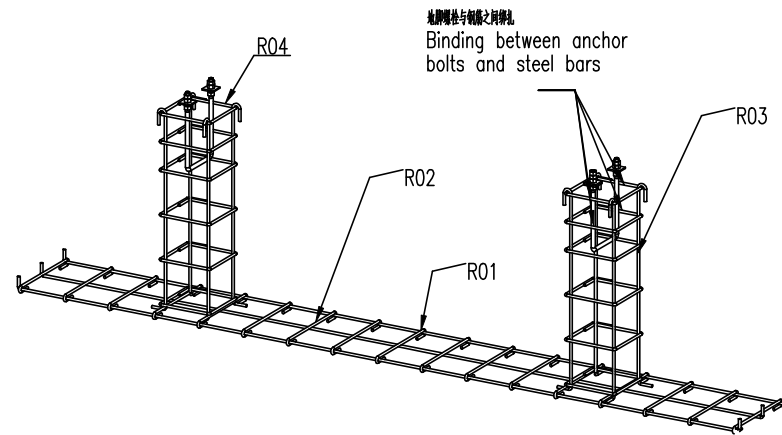
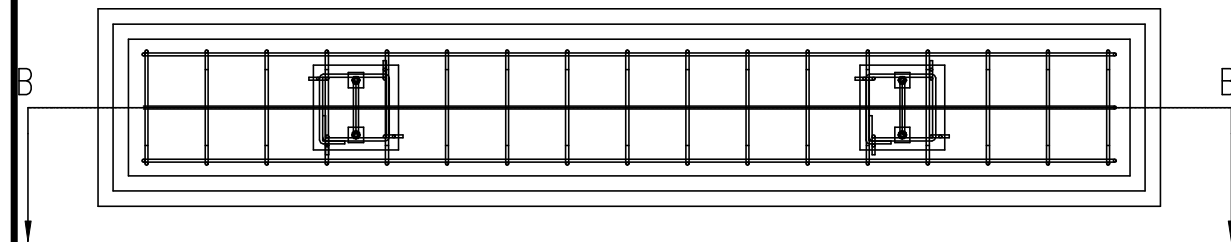
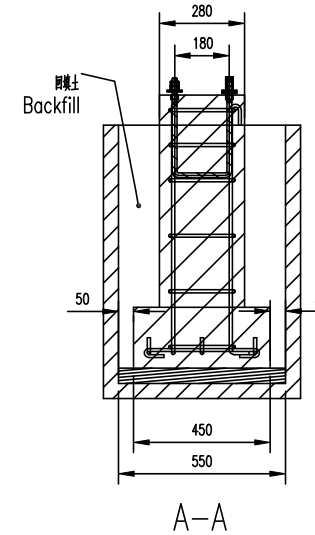
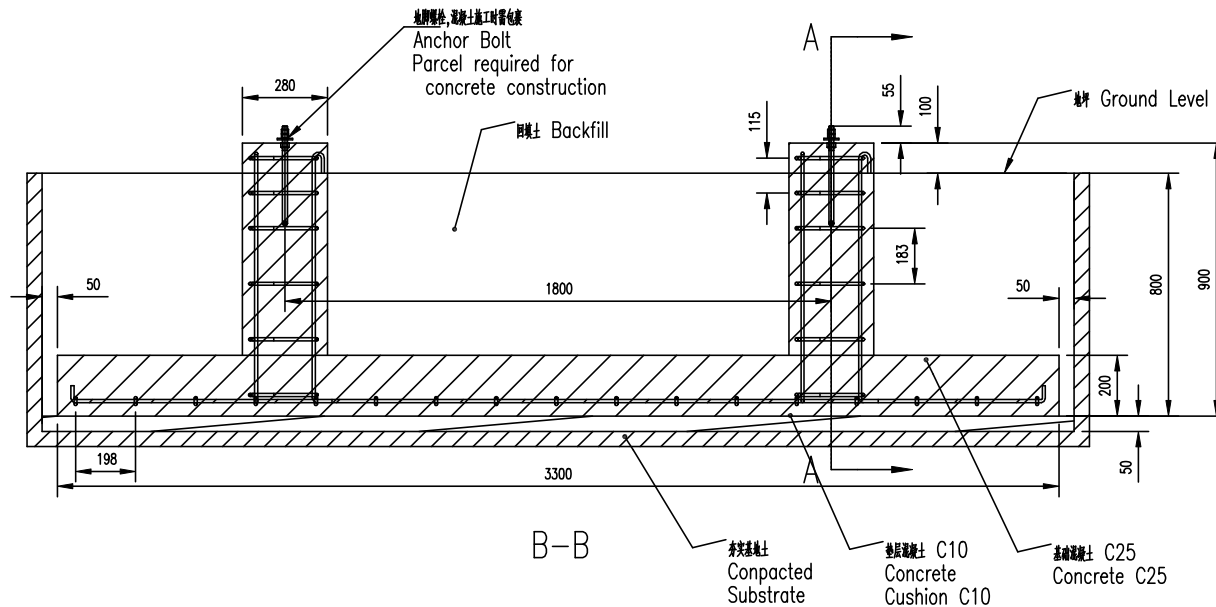

说明:

- Notes:
- 容许的施工误差: $\pm 3\text{mm}$;
Allow scope of Construction error: $\pm 3\text{mm}$;
 - 设计基本风速与仰角有关。
基底土承载力不小于 100kPa 。
The design basic wind speed is related to the elevation angle.
Basal soil bearing capacity(f_{ak}) should be more than 100kPa ,
除特别说明外,所有长度的单位均为mm;
 - All dimensions are millimeter unless otherwise stated;
 - 钢筋屈服强度: 335MPa ($d=10\text{mm}$);
Yield strength (yield point) of steel: 335MPa ($d=10\text{mm}$);
 - 基础混凝土:C25;垫层混凝土:C10
Concrete of Foundation:C25; Concrete Cushion: C10
 - 若未特别说明,基础保护层厚度一律采用50mm;
Thickness of Concrete Cover is 50mm unless otherwise stated;
 - 浇注混凝土前必须校正基础模板位置和尺寸正确;
Verify base dimension before casting concrete;
 - 基础浇注过程中必须进行振捣;
Vibration of concrete should be performed during pouring concrete;
 - 基础浇注完成后需养护至少3天;
Concrete surface should be kept wet for 3 days after casting;
 - 地脚螺栓绑在钢筋R04上。
Anchor bolt could be fixed on R04.

项目:

Project:

备注:

Remark:

图名:

Drawing title:

备注:

Remark:

编码:Part-No:

版本:Version:

比例:Scale:

结构编号:

设计:Designed:

检查:Checked:

审核:Verified:

批准:Approved:

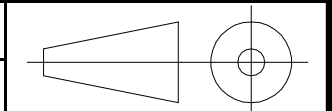

图号: NO.:

PV Module Support (Standard A-Shaped Support 3.0)

Quick Guide

Issue: 01

Part Number: 21540480, 21540481

Date: 2022-04-30

Huawei Technologies Co., Ltd.



Safety Precautions

■ Safety Precautions

When installing, operating, and maintaining the equipment, observe all the safety instructions on the equipment and in this document to prevent personal injury and equipment damage. The "WARNING", "CAUTION", "NOTICE", and "NOTE" statements in this document do not cover all the safety instructions. They are only supplements to the safety instructions. Follow all the safety precautions and instructions provided by Huawei. Huawei will not be liable for the consequences that are caused by the violation of the safety operation regulations and design, production, and usage standards.

■ Local Laws and Regulations

When operating the equipment, comply with local laws and regulations.

■ Personnel Requirements

Personnel who plan to install or maintain Huawei equipment must be qualified electricians who receive thorough product training, understand all necessary safety precautions, and are able to correctly perform all operations.

■ Symbol Conventions

NOTICE

Indicates a potentially hazardous situation which, if not avoided, could result in equipment damage, data loss, performance deterioration, or unanticipated results.

NOTE



















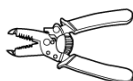
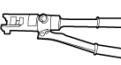



Supplements the important information in the main text.

■ Personal Safety

To prevent electric shocks, use insulated tools and wear insulation gloves when connecting cables.

To prevent personal injury, wear protective shoes when moving heavy objects.

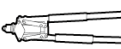
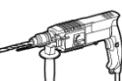
Preparing Tools

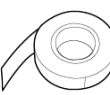
 Protective gloves	 Insulated gloves	 Work shoes	 Safety helmet	 Compass	 Steel measuring tape
 Falsework	 Ladder	 Power cable cutter	 Wire stripper	 Hydraulic pliers	 Crimping tool
 Diagonal pliers	 Needle-nose pliers	 Adjustable torque wrench	 Insulated socket wrench	 Adjustable wrench	 Inner hex key
 Marker	 Level	 Insulated torque screwdriver	 Heat gun	 Rivet gun	 Hammer drill
 Heat shrink tubing	 Cloth insulation tape				

Components of a Standard A-Shaped Support (Low Support)

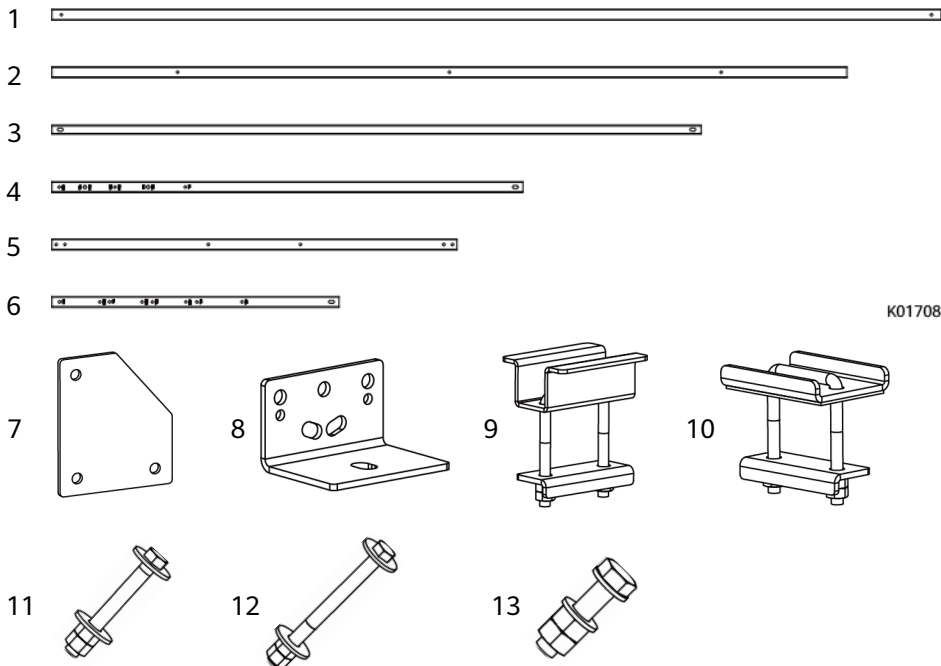

K01708

No.	Item	Length (mm)	Quantity (PCS)
1	Horizontal beam	4089	4
2	Longitudinal beam	3656	2
3	Reinforced beam	2986	1
4	Long raking strut	2165	2
5	Column	1862	4
6	Short raking strut	1321	2
7	Column bracket	/	4
8	Anchor bracket	/	8
9	PV module middle clamp	/	9 (including one spare part)
10	PV module edge clamp	/	9 (including one spare part)
11	M12x100 bolt	/	15 (including one spare part)
12	M12x140 bolt	/	19 (including one spare part)
13	M8x35 bolt	/	2 (including one spare part)

Installed Standard A-Shaped Support (Low Support)

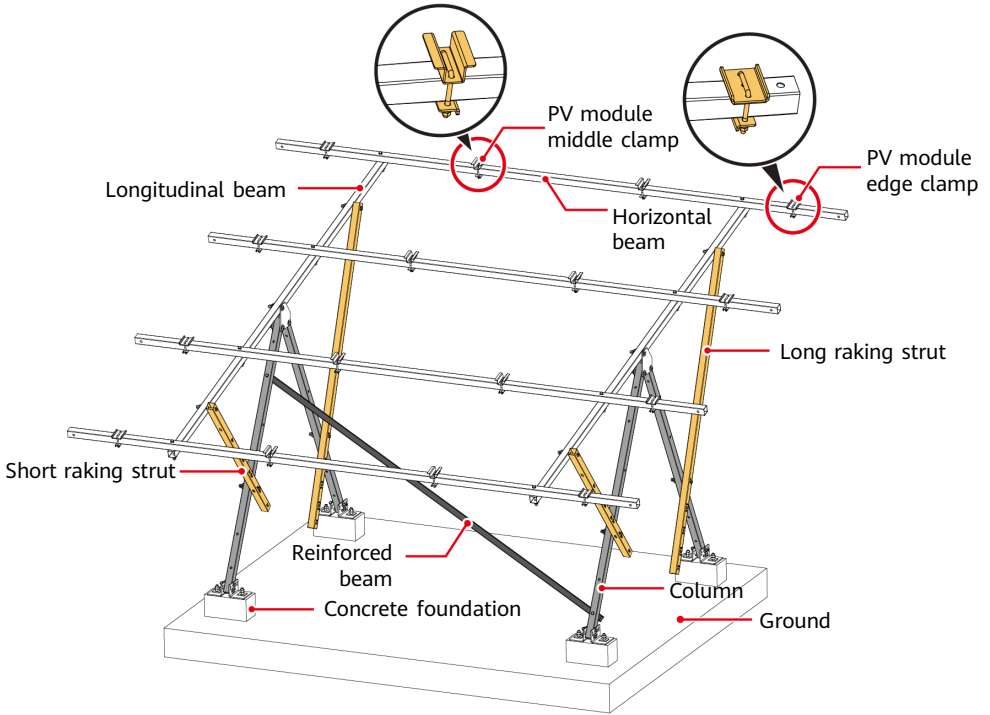

K01400

NOTE

In the figure, the PV module (540 W) tilt angle is 15° .

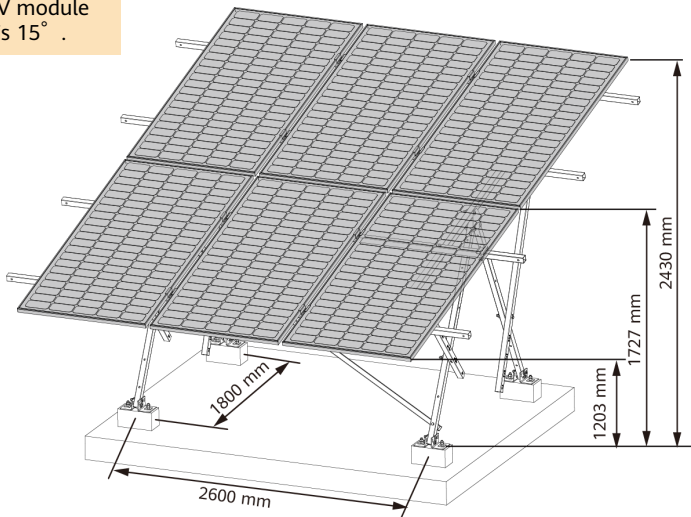

K01401

Components of a Standard A-Shaped Support (High Support)

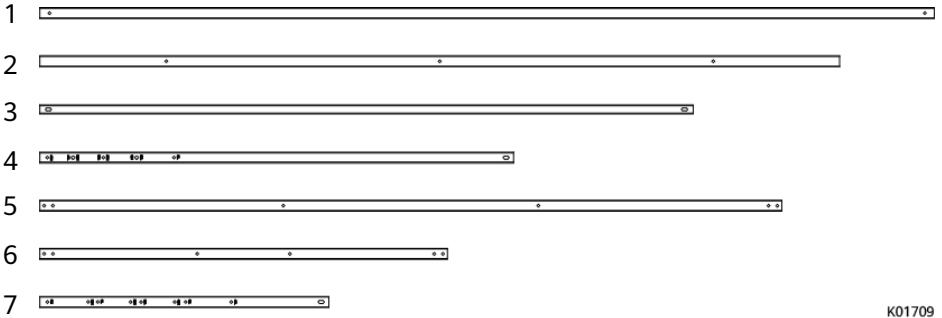

K01709

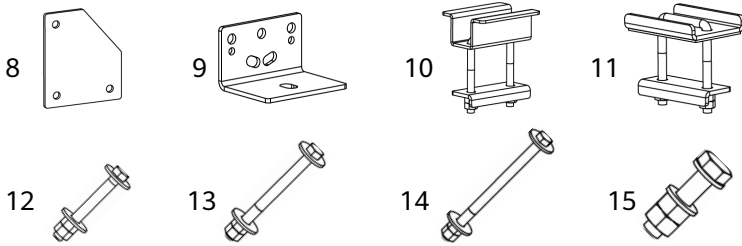

No.	Item	Length (mm)	Quantity (PCS)
1	Horizontal beam	4089	4
2	Longitudinal beam	3656	2
3	Reinforced beam	2986	2
4	Long raking strut	2165	2
5	High column	3391	4
6	Low column	1862	4
7	Short raking strut	1321	4
8	Column bracket	/	4
9	Anchor bracket	/	8
10	PV module middle clamp	/	9 (including one spare part)
11	PV module edge clamp	/	9 (including one spare part)
12	M12x100 bolt	/	19 (including one spare part)
13	M12x140 bolt	/	29 (including one spare part)
14	M12x180 bolt	/	3 (including one spare part)
15	M8x35 bolt	/	2 (including one spare part)

Installed Standard A-Shaped Support (High Support)

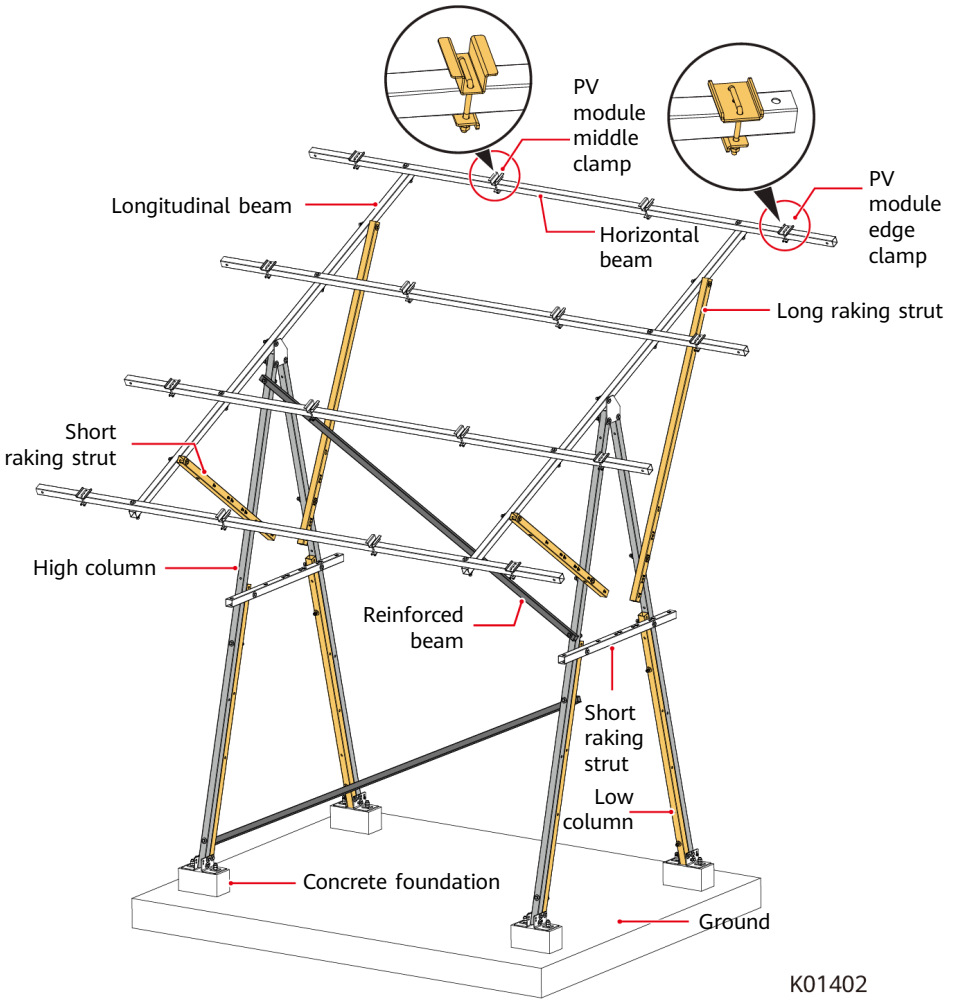

NOTE

In the figure, the PV module (540 W) tilt angle is 25° .

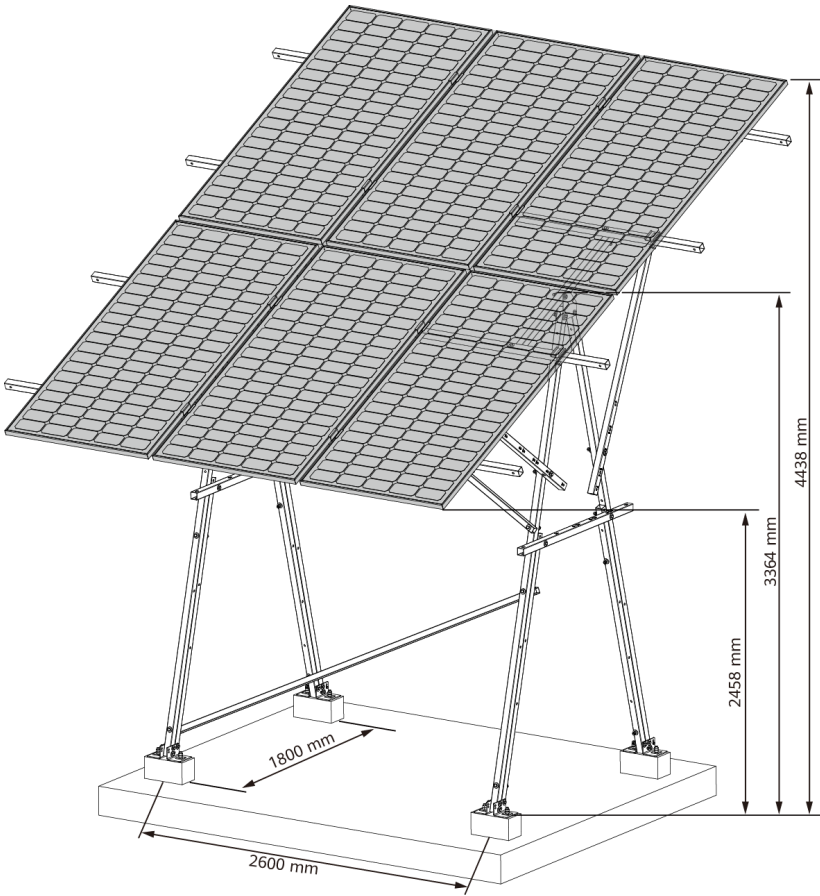

K01403

Standard A-Shaped Support (Low Support)

1 Installing a PV Module Support

1.1 Determining the Direction and Tilt Angle of PV Modules

Determine the orientation of PV modules based on design requirements. In the northern hemisphere, PV modules face south. In the southern hemisphere, PV modules face north. The following table lists the tilt angle design specifications.

Site Latitude (Degree)	0–15	16–25	26–30	31–45
PV Module Tilt Angle (Degree)	15	25	35	45

1.2 Installing a PV Module Support

NOTICE

- The PV module support can be mounted with 540 W PV modules or iPV540-M1A.
- When installing mechanical parts, use two nuts to secure the bolts. Tighten the inner nut first and then the outer nut. After the nuts are tightened, ensure that the flats on the two nuts are not aligned. (Use a wrench to secure the inner nut and use another wrench to tighten the outer nut.)
- When installing a support, use a marker to mark each bolt after tightening.
- In steps 1 to 4, partially tighten the bolts to reserve space for adjustment. Then, tighten the bolts in step 6.

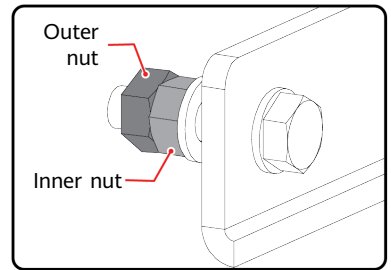

1. Install connecting plates on columns. (Partially tighten the bolts.)

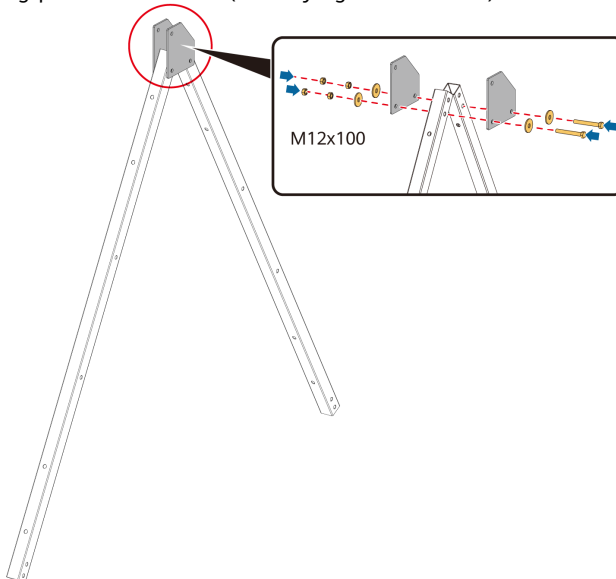

K01605

2. Install a longitudinal beam. (Partially tighten the bolts.)

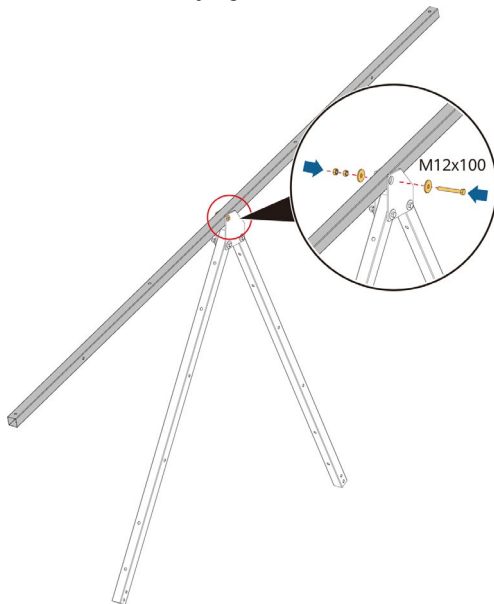

K01604

3. Install a long raking strut and short raking strut. (Partially tighten the bolts.)

NOTICE

- The short raking strut needs to be installed on the lower side of a PV module support, and the long raking strut needs to be installed on the higher side of a PV module support.
- When installing raking struts, partially tighten them first. After anchor bolts are installed, tighten the raking struts.
- The holes in the long and short raking struts are silkscreened. Determine the holes for mounting based on the tilt angle of PV modules and support type. The following figure uses the installation of raking struts for a low support for 45° PV modules as an example. In this case, the raking struts need to be mounted through the holes marked with 45L.

Raking strut mounting hole for a low support for 45° PV modules

Raking strut mounting hole for a low support for 35° PV modules

Raking strut mounting hole for a low support for 25° PV modules

Raking strut mounting hole for a low support for 15° PV modules



Raking strut mounting hole for a low support for 15° PV modules

Raking strut mounting hole for a low support for 25° PV modules

Raking strut mounting hole for a low support for 35° PV modules

Raking strut mounting hole for a low support for 45° PV modules

K01607

Short raking strut Long raking strut

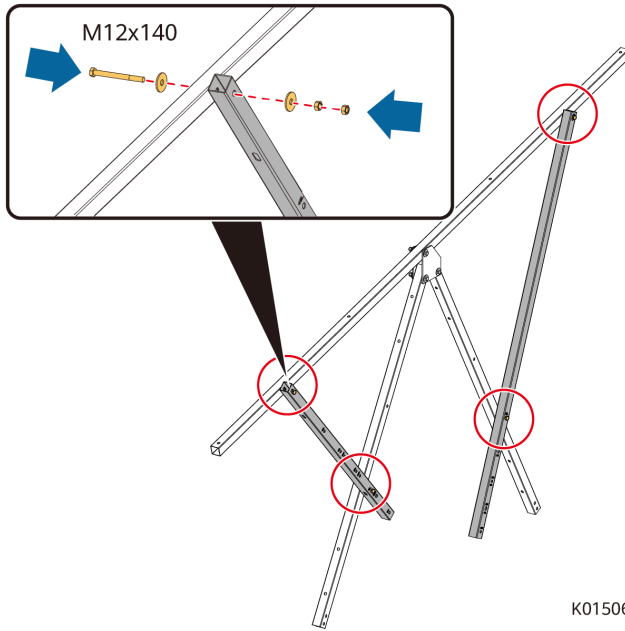

4. Install anchor brackets. (Partially tighten the bolts.)

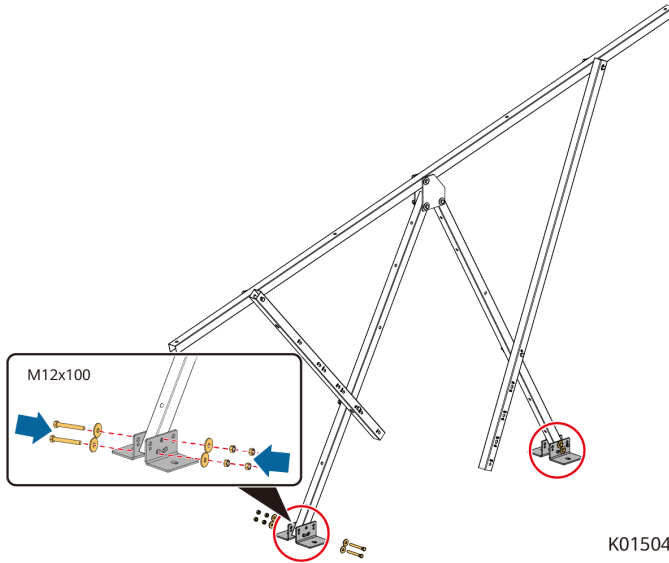

5. Loosen the washers and nuts of the anchor bolts, fix the support assemblies to the foundation, and tighten the anchor bolts.

NOTICE

- Ensure that lower edge of the longitudinal beam faces the equator.
- When installing anchor bolts, secure each bolt using two nuts.

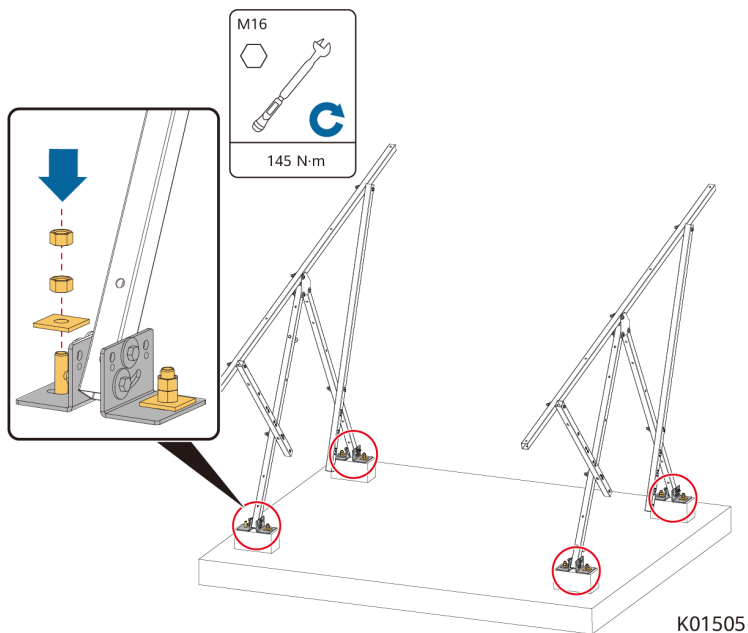

K01505

6. Tighten all bolts partially tightened on the support assemblies to 45 N-m.
7. Install horizontal beams.

NOTE

Ensure that the bolts are inserted from the front side of the beam.

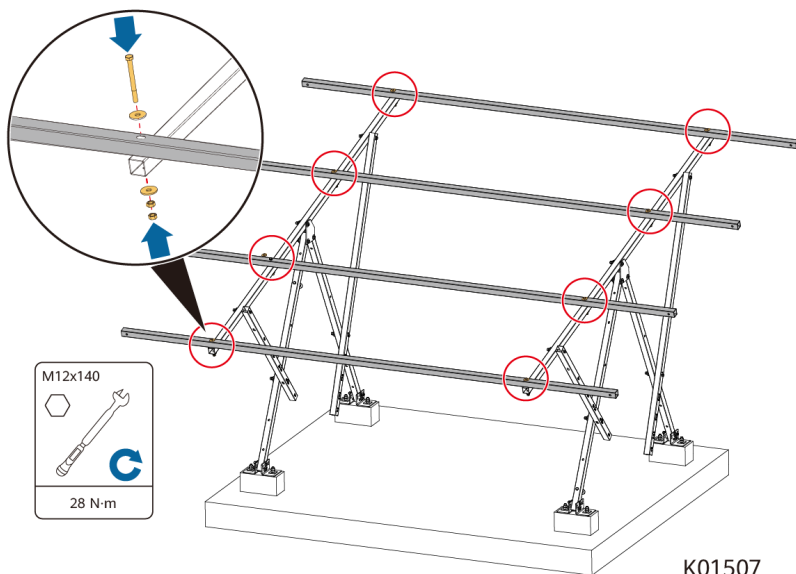

K01507

8. Install reinforced beams.

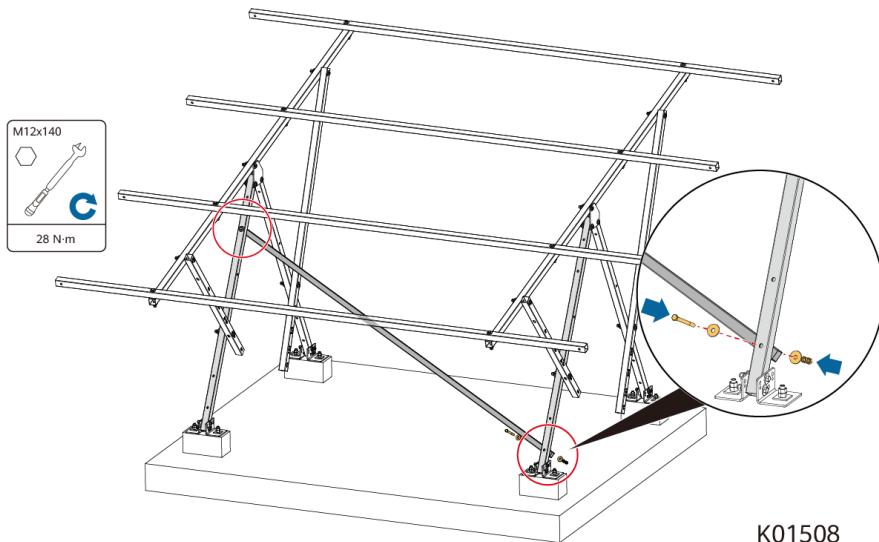

K01508

9. Install edge clamps and middle clamps for PV modules.

NOTICE

- Partially tighten all the clamps.
- When installing the rubber pad, ensure that the adhesive side faces upwards. Remove the adhesive sticker and press the rubber pad to ensure that it is firmly attached.
- The nuts for securing PV module clamps are classified into common nuts and antitheft nuts. Select nuts based on the actual configuration.
- Use an antitheft nut wrench to partially tighten antitheft nuts.

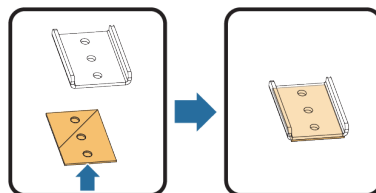

Antitheft nut

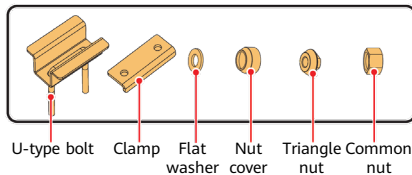
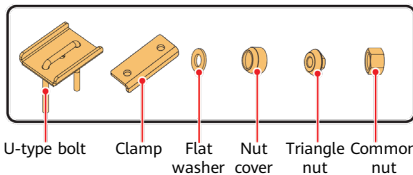

Common nut

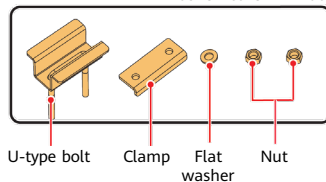
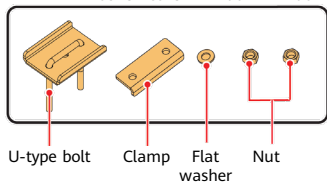

K01039

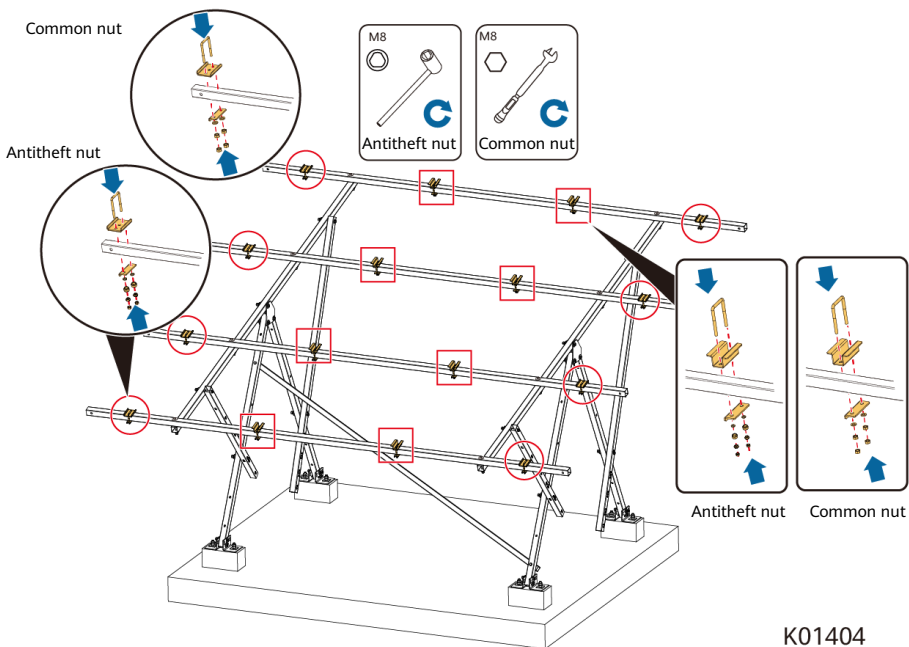

K01404

10. Install PV modules.

NOTICE

- When installing PV modules, ensure that the distances between the PV module edges and the two ends of the support horizontal beam are the same.
- When installing PV modules, ensure that the control boxes behind PV modules face the same direction.
- The following table lists the dimensions of PV modules that can be mounted on a support.

PV Module Specifications	Dimensions (mm)		
	Length	Width	Thickness
540 W/iPV540-M1A	2256-2285	1133-1134	35

Applicable to 540 W PV Modules

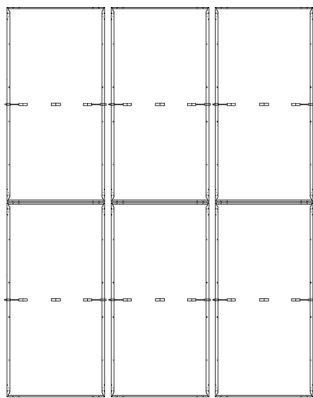

Applicable to iPV540-M1A PV Modules

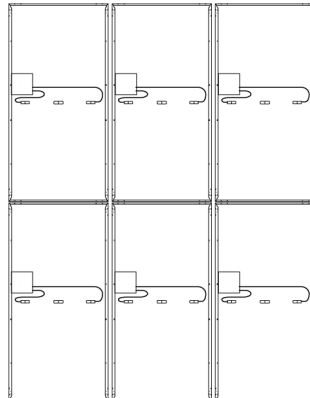

11. Adjust the positions of clamps to secure the PV modules. Then tighten the screws.

NOTICE

When fixing PV modules, ensure that the edge clamps and the middle clamps are tightly attached to the inner and outer sides of the PV modules, respectively.

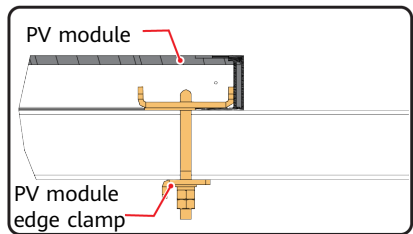
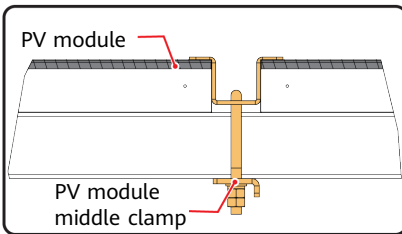
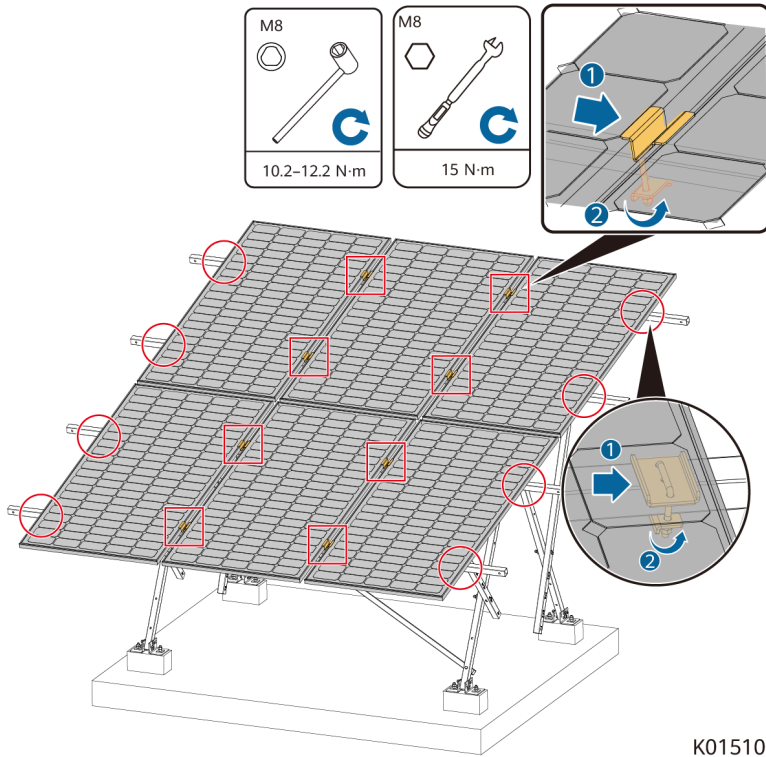

K01040

2 Installing Cables for PV Modules

1. Install ground screws and a ground cable for PV modules.

NOTE

Install ground screws near the ground bar.

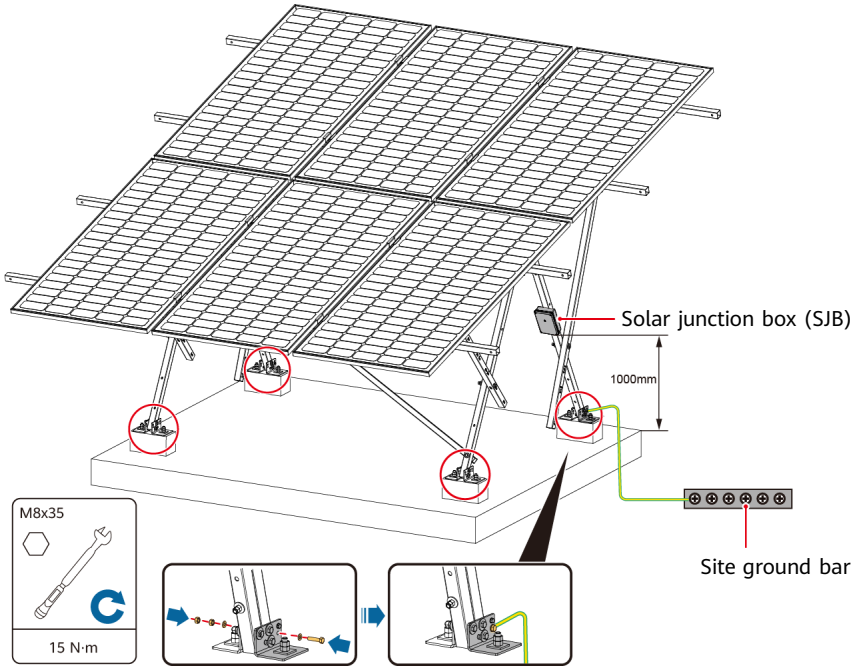

K01509

2. Install DC power cables for PV modules.

NOTICE

If the DC power cables to PV modules are not long enough, connect the extension cables.

Installing 540 W PV Modules (Connecting to an SJB)

Connect two PV modules in series as a route and connect the route to the SJB.

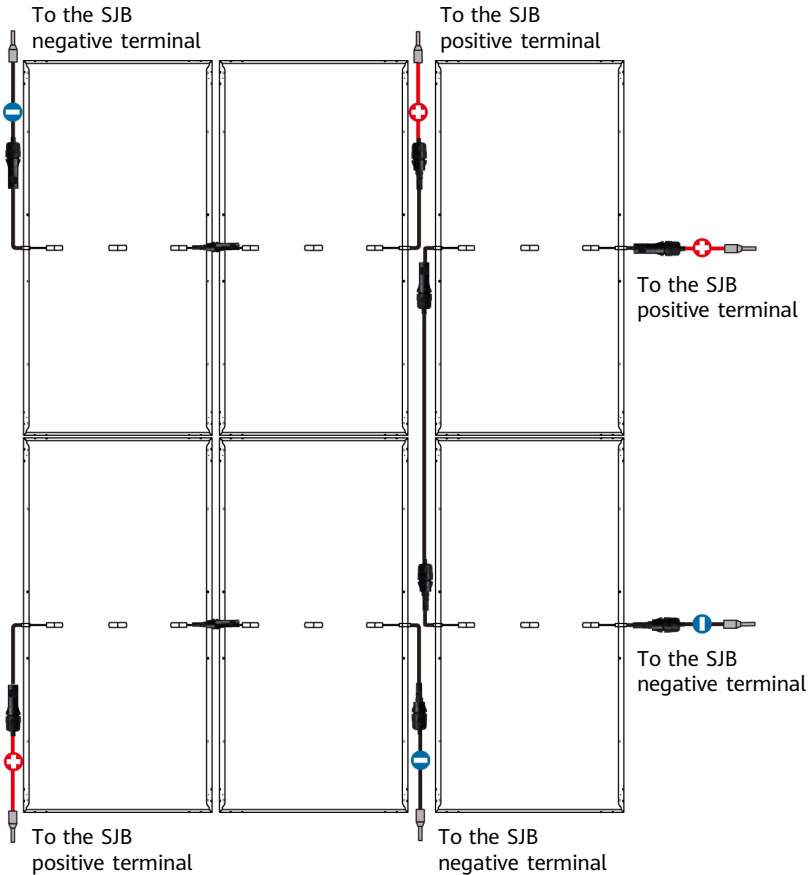

K01701

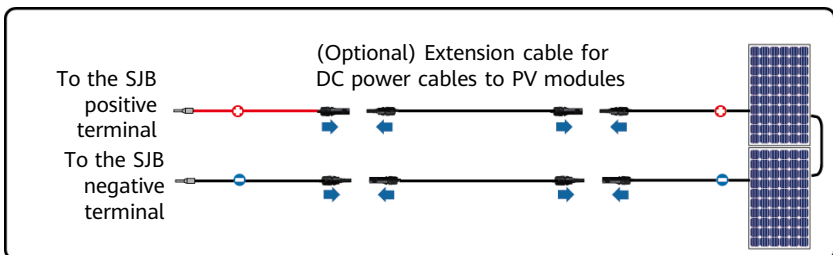

K01706

Installing 540 W PV Modules (Connecting to a PVPU)

Connect all PV modules in series and then connect them to the photovoltaic power unit (PVPU).

NOTICE

Three to eight PV modules can be connected in series. The following shows how to connect six PV modules in series.

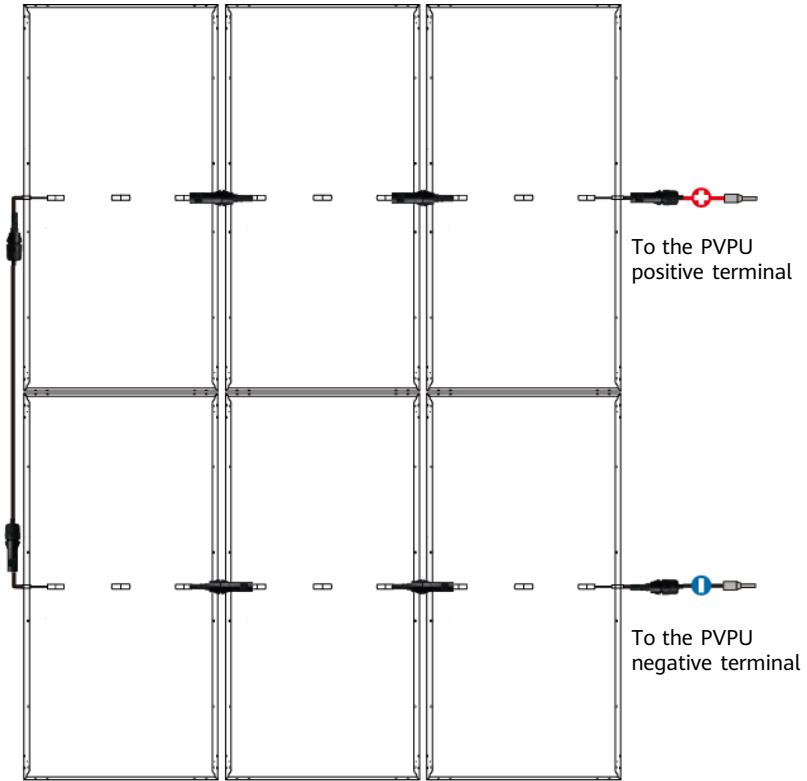

K01704

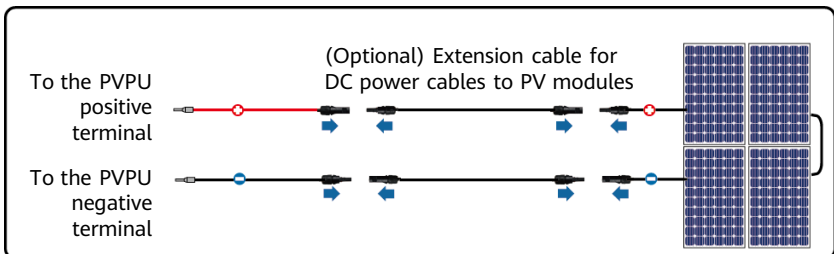

K01703

Installing iPV540-M1A PV Modules

When installing the iPV540-M1A, connect all PV modules in series and then connect them to the PVPU.

NOTICE

Three to eight PV modules can be connected in series. The following shows how to connect six PV modules in series.

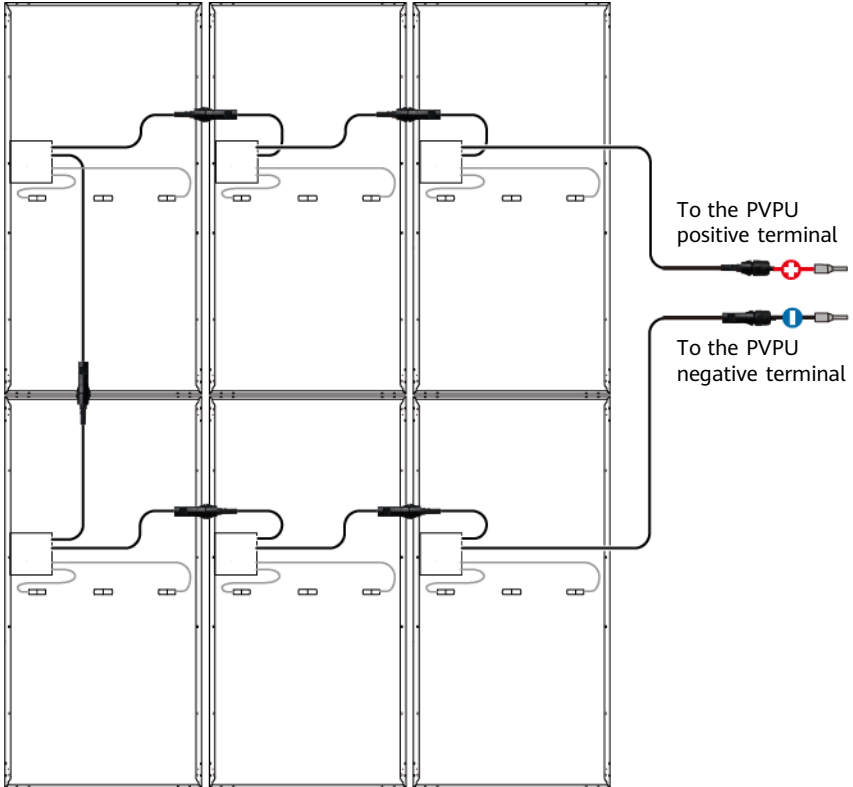

K01705

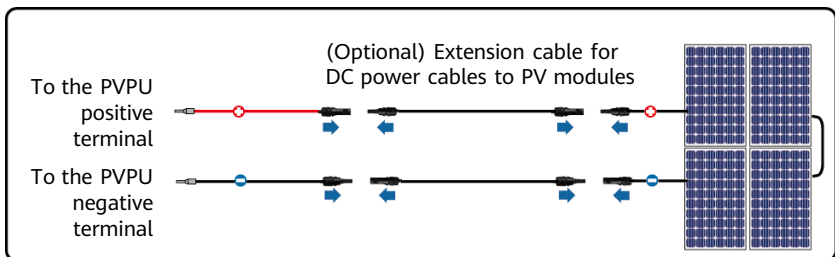

K01703

Standard A-Shaped Support (High Support)

1 Installing a PV Module Support

1.1 Determining the Direction and Tilt Angle of PV Modules

Determine the orientation of PV modules based on design requirements. In the northern hemisphere, PV modules face south. In the southern hemisphere, PV modules face north. The following table lists the tilt angle design specifications.

Site Latitude (Degree)	0-15	16-25	26-30	31-45
PV Module Tilt Angle (Degree)	15	25	35	45

1.2 Installing a PV Module Support

NOTICE

- The PV module support can be mounted with 540 W PV modules or iPV540-M1A.
- When installing mechanical parts, use two nuts to secure the bolts. Tighten the inner nut first and then the outer nut. After the nuts are tightened, ensure that the flats on the two nuts are not aligned. (Use a wrench to secure the inner nut and use another wrench to tighten the outer nut.)
- When installing a support, use a marker to mark each bolt after tightening.
- In steps 1 to 4, partially tighten the bolts to reserve space for adjustment. Then, tighten the bolts in step 6.

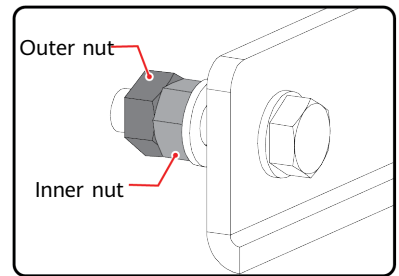

K01043

1. Install connecting plates on high columns. (Partially tighten the bolts.)

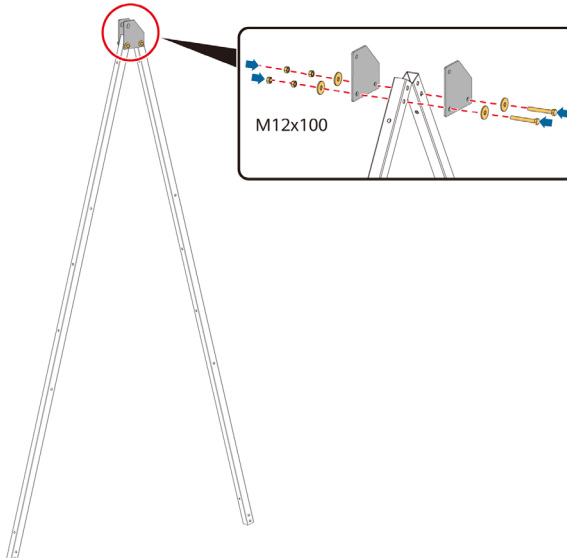

K01606

2. Install a longitudinal beam.
(Partially tighten the bolts.)

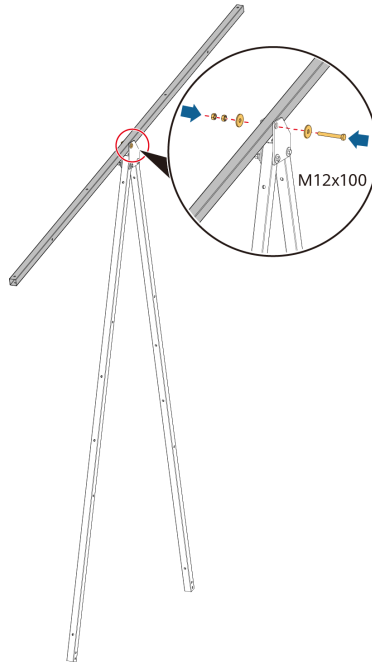

K01603

3. Install a long raking strut and short raking strut. (Partially tighten the bolts.)

NOTICE

- The short raking strut needs to be installed on the lower side of a PV module support, and the long raking strut needs to be installed on the higher side of a PV module support.
- When installing raking struts, partially tighten them first. After anchor bolts are installed, tighten the raking struts.
- The holes in the long and short raking struts are silkscreened. Determine the holes for mounting based on the tilt angle of PV modules and support type. The following figure uses the installation of raking struts for a high support for 45° PV modules as an example. In this case, the raking struts need to be mounted through the holes marked with 45H.

Raking strut mounting hole for a high support for 45° PV modules

Raking strut mounting hole for a high support for 35° PV modules

Raking strut mounting hole for a high support for 25° PV modules

Raking strut mounting hole for a high support for 15° PV modules

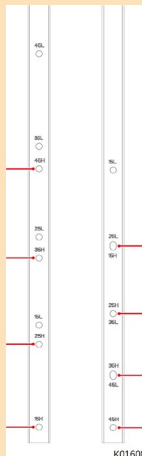

K01608

Raking strut mounting hole for a high support for 15° PV modules

Raking strut mounting hole for a high support for 25° PV modules

Raking strut mounting hole for a high support for 35° PV modules

Raking strut mounting hole for a high support for 45° PV modules

Short raking strut Long raking strut

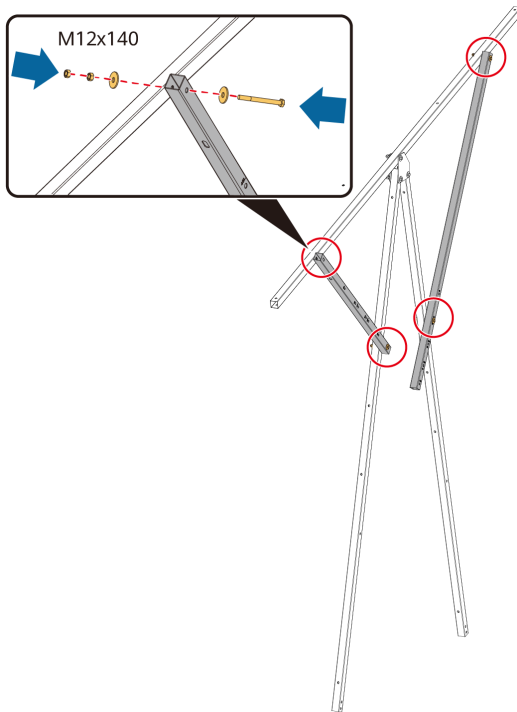

K01602

4. Install low columns. (Partially tighten the bolts.)

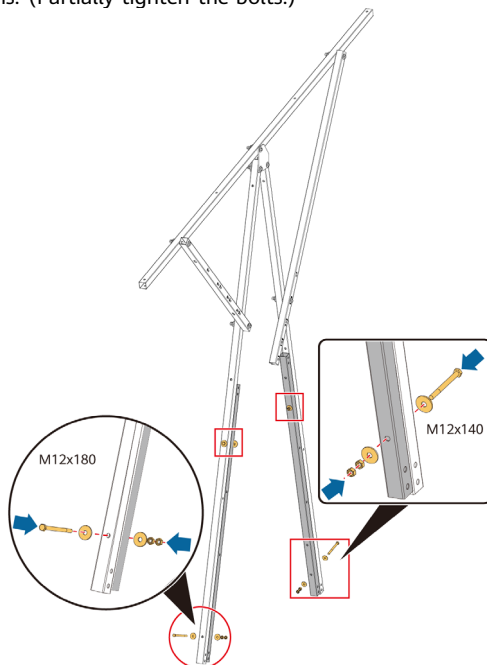

K01601

5. Install a short raking strut. (Partially tighten the bolts.)

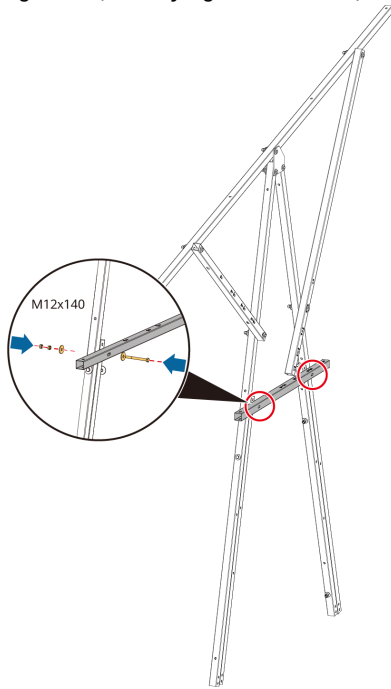

K01514

6. Install anchor brackets. (Partially tighten the bolts.)

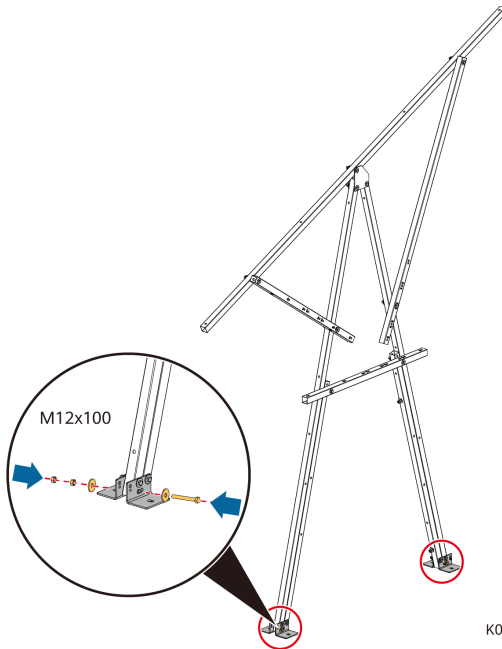

K01405

- Loosen the washers and nuts of the anchor bolts, fix the support assemblies to the foundation, and tighten the anchor bolts.

NOTICE

- Ensure that lower edge of the longitudinal beam faces the equator.
- When installing anchor bolts, secure each bolt using two nuts.

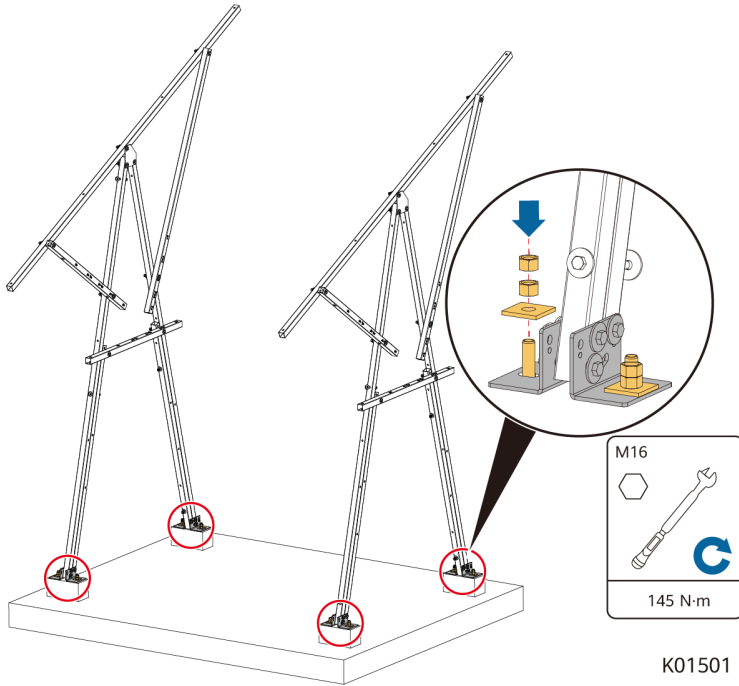

- Tighten all bolts partially tightened on the support assemblies to 45 N·m.
- Install horizontal beams.

NOTICE

Ensure that the bolts are inserted from the front side of the beam.

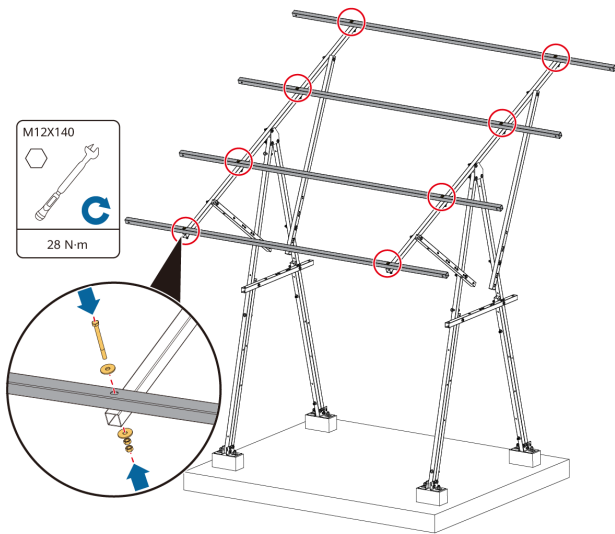

K01502

10. Install reinforced beams.

NOTE

Loosen the M12x180 bolts that are partially tightened before installing reinforced beams.

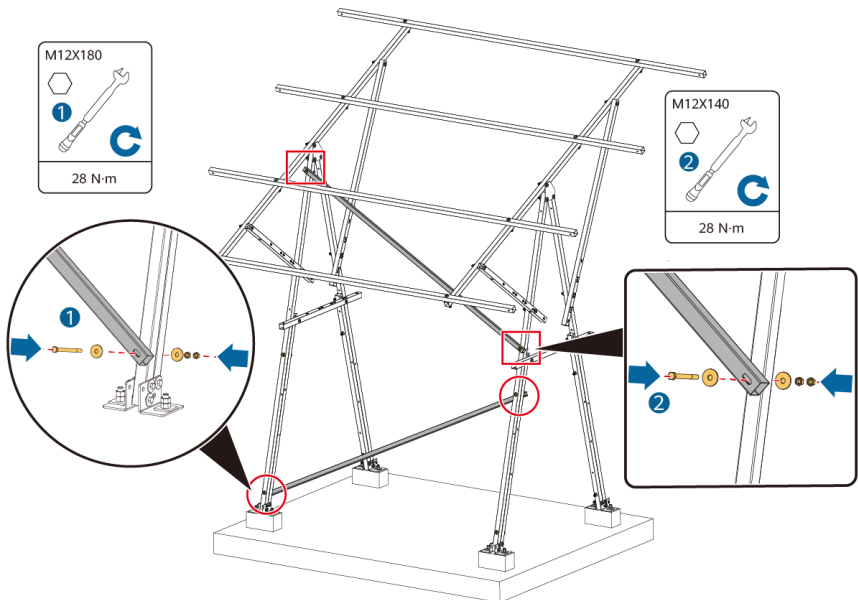

K01503

11. Install edge clamps and middle clamps for PV modules.

NOTICE

- Partially tighten all the clamps.
- When installing the rubber pad, ensure that the adhesive side faces upwards. Remove the adhesive sticker and press the rubber pad to ensure that it is firmly attached.
- The nuts for securing PV module clamps are classified into common nuts and antitheft nuts. Select nuts based on the actual configuration.
- Use an antitheft nut wrench to partially tighten antitheft nuts.

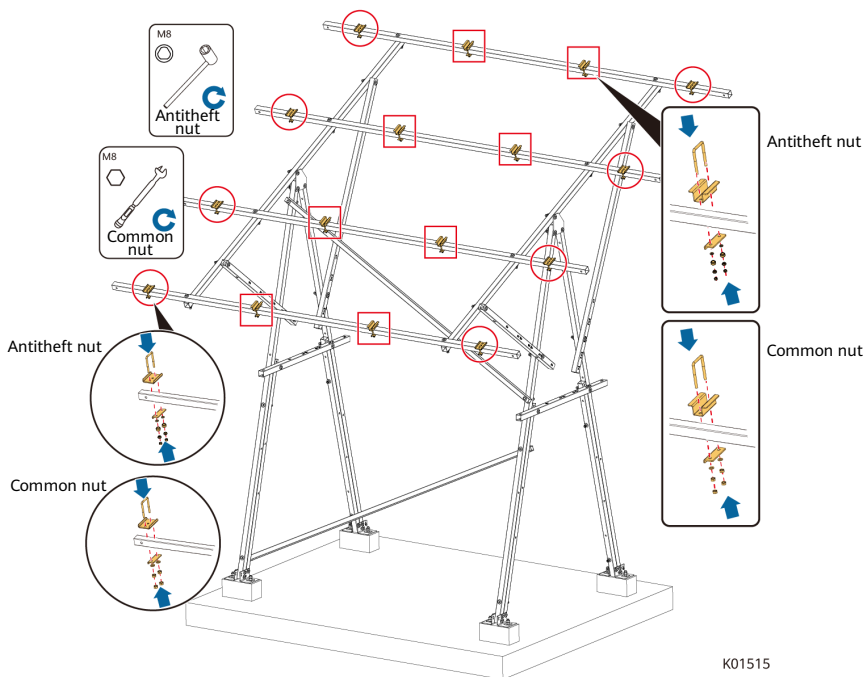
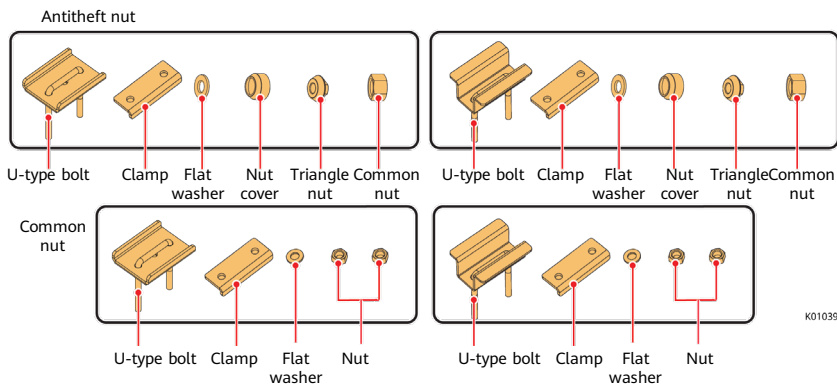
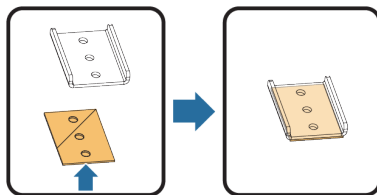

12. Install PV modules.

NOTICE

- When installing PV modules, ensure that the distances between the PV module edges and the two ends of the support horizontal beam are the same.
- When installing PV modules, ensure that the control boxes behind PV modules face the same direction.
- The following table lists the dimensions of PV modules that can be mounted on a support.

PV Module Specifications	Dimensions (mm)		
	Length	Width	Thickness
540 W/iPV540-M1A	2256-2285	1133-1134	35

Applicable to 540 W PV Modules

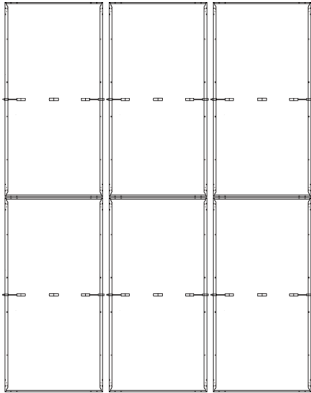

K01702

Applicable to iPV540-M1A PV Modules

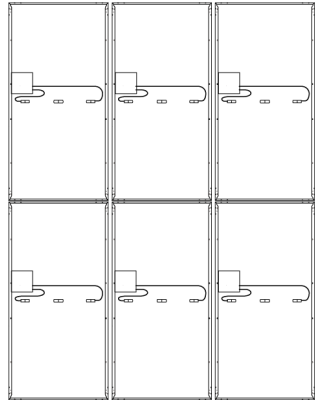

K01702

13. Adjust the positions of clamps to secure the PV modules. Then tighten the screws.

NOTE

When fixing PV modules, ensure that the edge clamps and the middle clamps are tightly attached to the inner and outer sides of the PV modules, respectively.

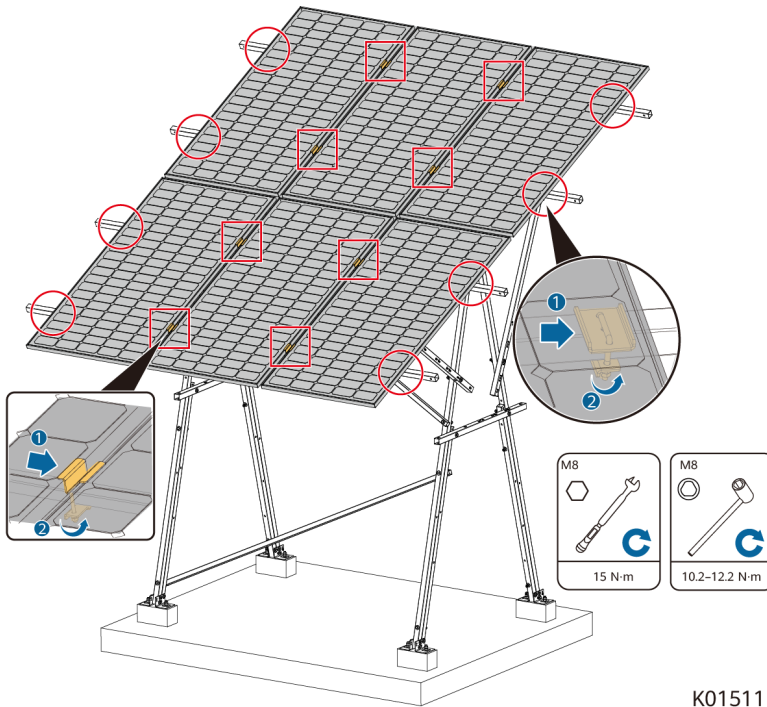

K01511

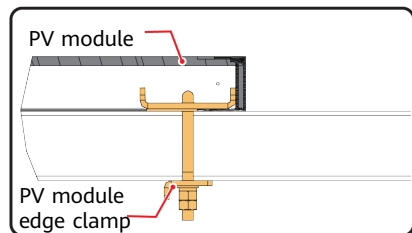
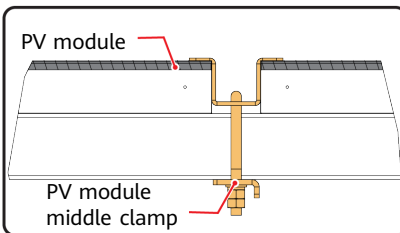

K01040

2 Installing Cables for PV Modules

1. Install ground screws and a ground cable for PV modules.

NOTICE

Install ground screws near the ground bar.

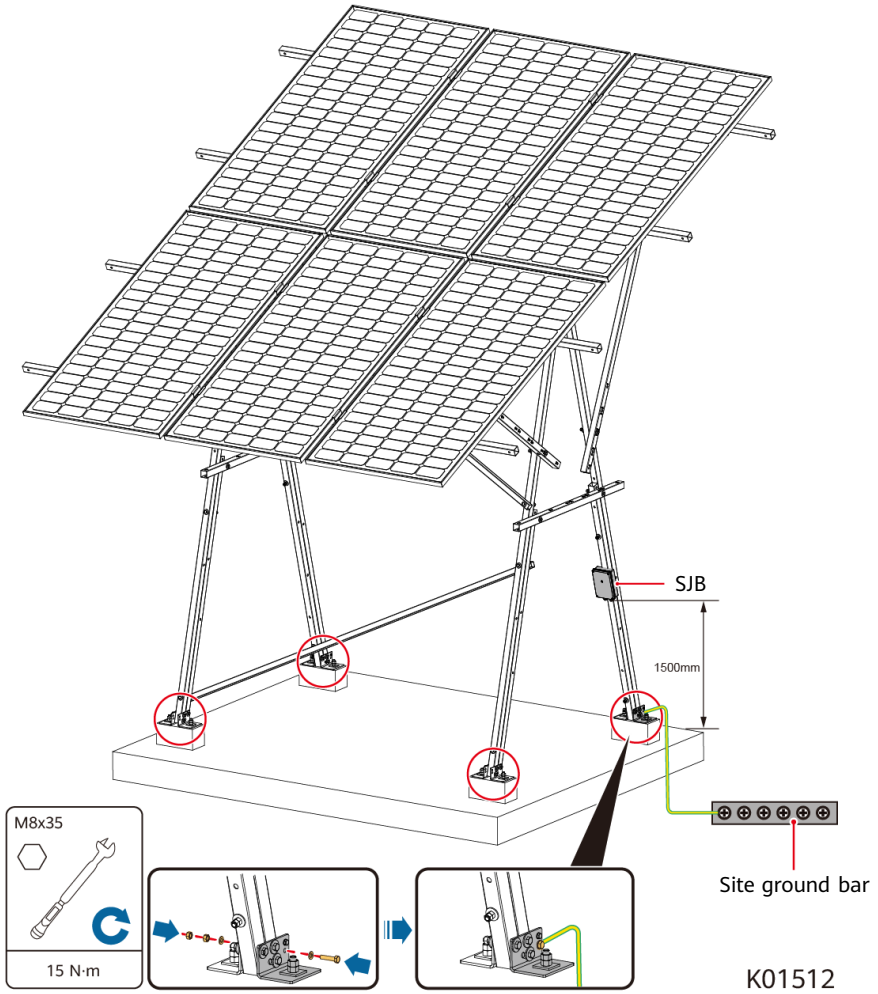

2. Install DC power cables for PV modules.

NOTICE

If the DC power cables to PV modules are not long enough, connect the extension cables.

Installing 540 W PV Modules (Connecting to an SJB)

Connect two PV modules in series as a route and connect the route to the SJB.

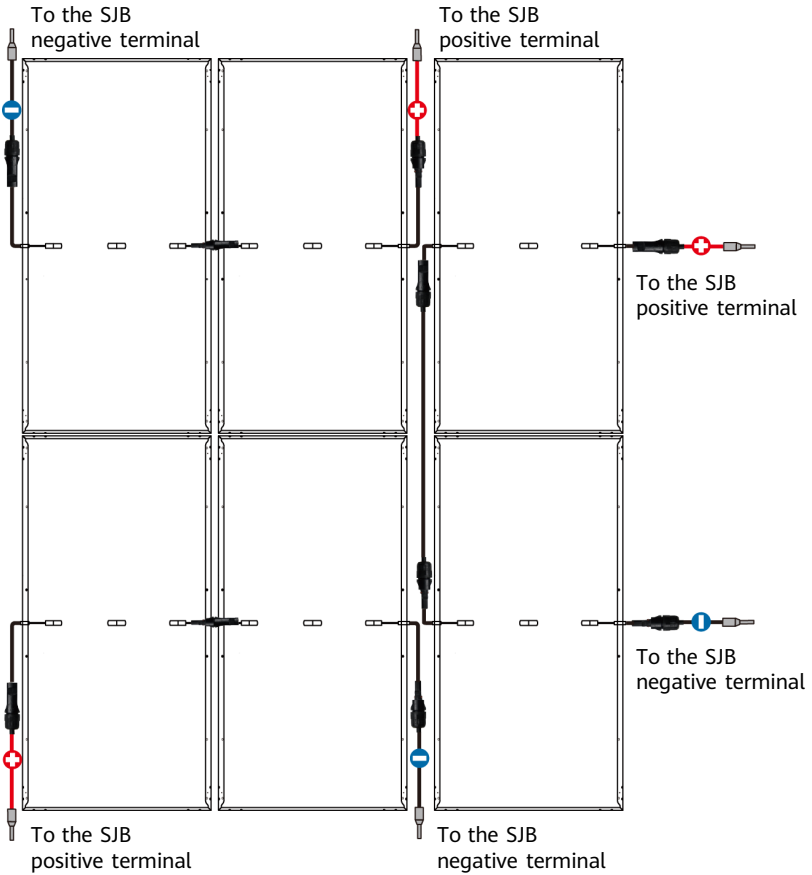

K01701

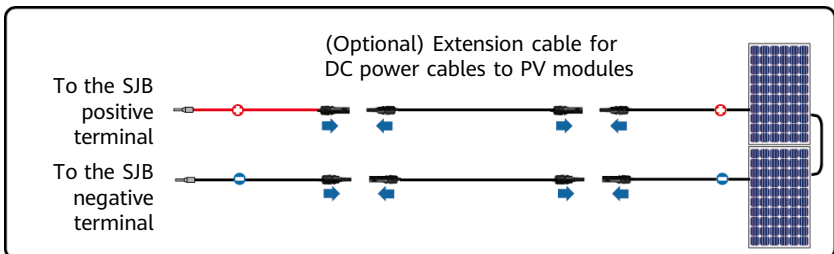

K01706

Installing 540 W PV Modules (Connecting to a PVPU)

Connect all PV modules in series and then connect them to the PVPU.

NOTICE

Three to eight PV modules can be connected in series. The following shows how to connect six PV modules in series.

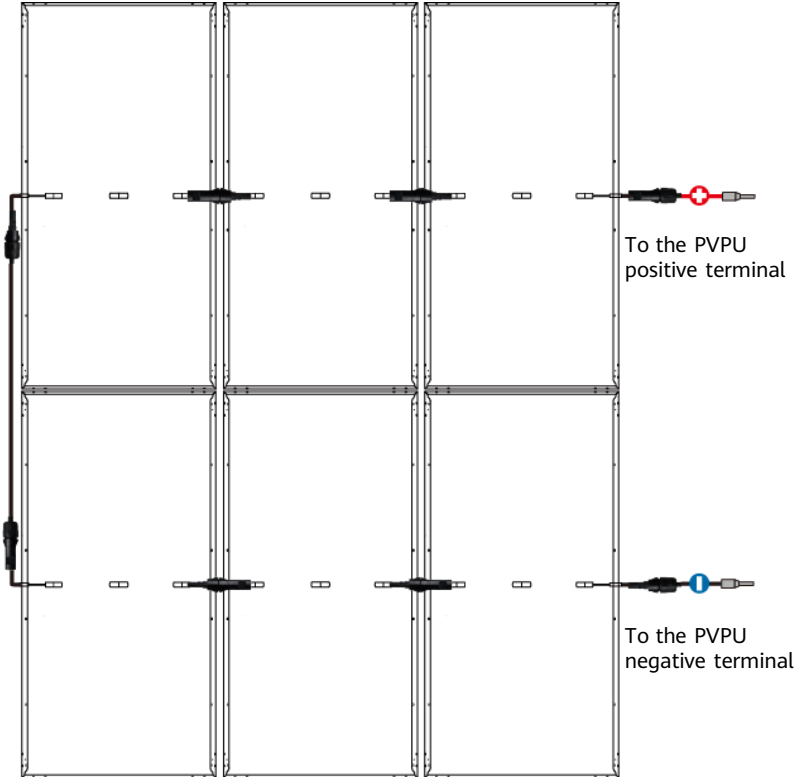

K01704

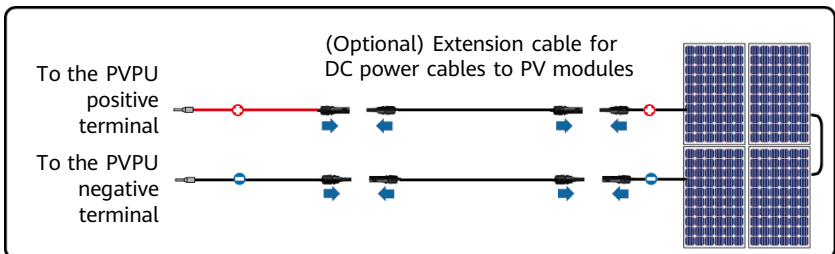

K01703

Installing iPV540-M1A PV Modules

When installing the iPV540-M1A, connect all PV modules in series and then connect them to the PVPU.

NOTICE

Three to eight PV modules can be connected in series. The following shows how to connect six PV modules in series.

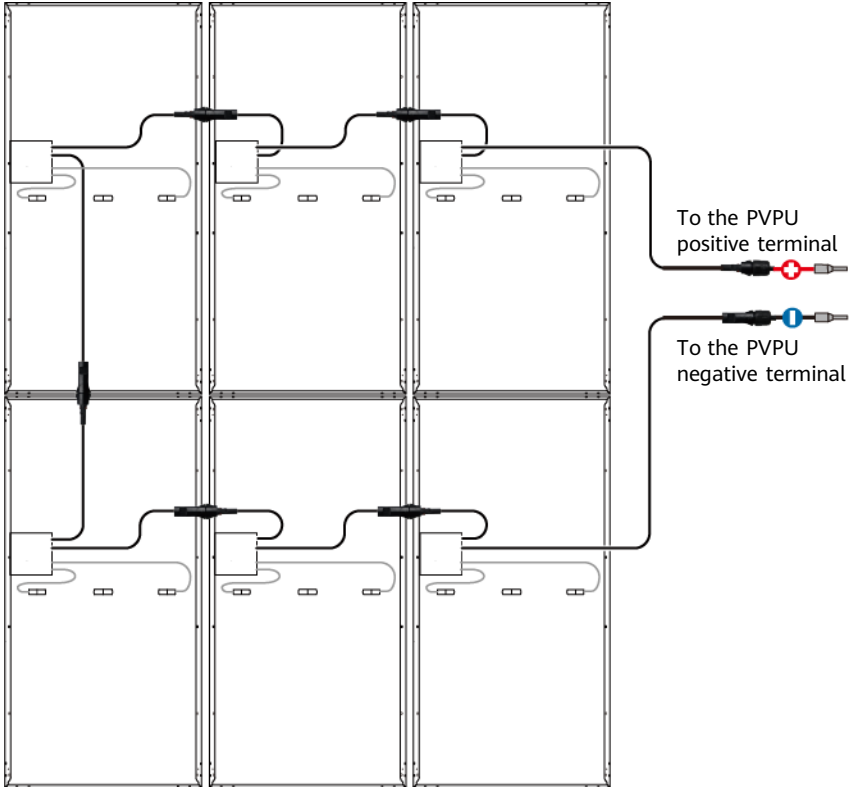

K01705

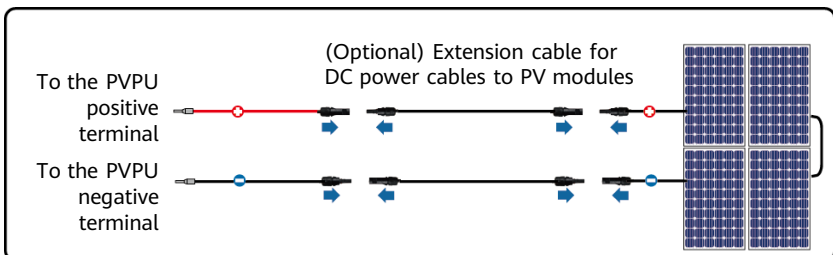

K01703

Appendix

1 (Optional) Installing a Standard SJB

1. Install an SJB.

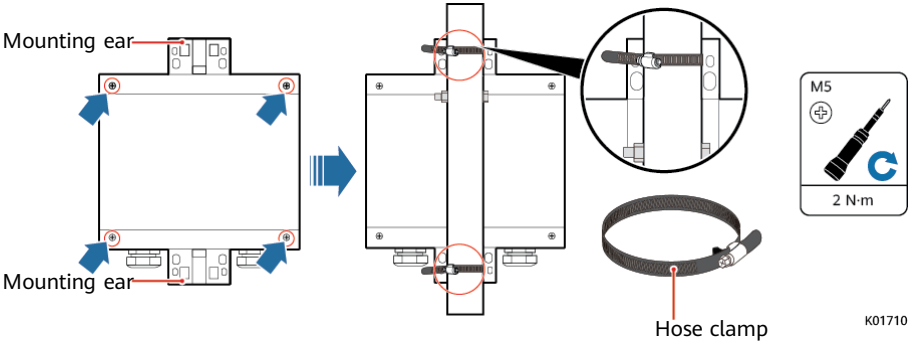

2. Install cables between PV modules and the SJB.

PV Module Type	Installation mode	Maximum Routes Connected to the SJB
540 W PV module	Every two PV modules are connected in series as one route.	4 (if configured with a 4 kW SSU) 3 (if configured with a 3 kW SSU)

NOTE

The figure shows how to connect one route to the SJB.

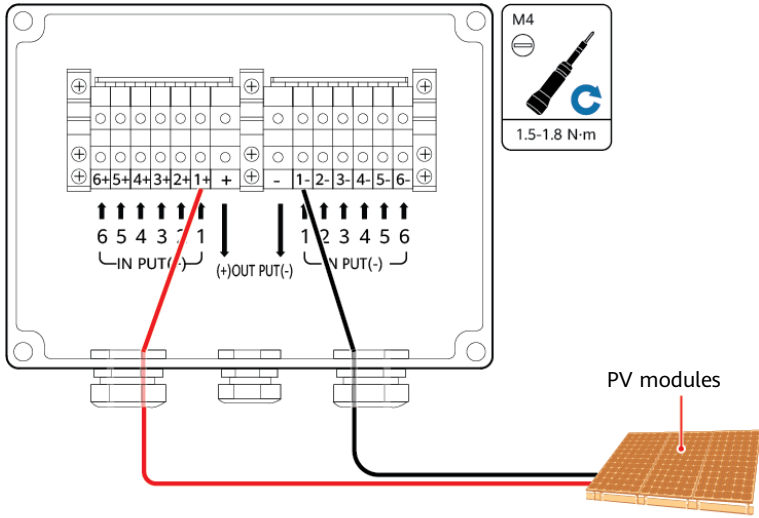

2 (Optional) Installing an SJB-0601A

1. Install a metal base.

Securing with Screws

- ① Mark mounting holes in an appropriate area on the wall.

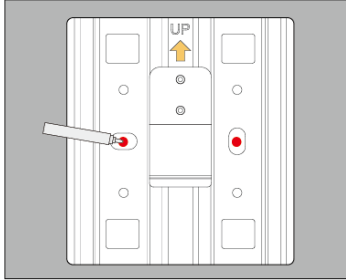

PC00H0038

- ② Drill holes in the marked positions.

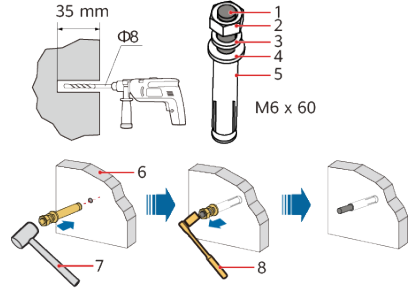

PO01HC0549

- (1) Expansion anchor bolt (2) M6 nut (3) Spring washer (4) Flat washer (5) Expansion sleeve (6) Wall (7) Rubber mallet (8) Socket wrench

- ③ Secure the base.

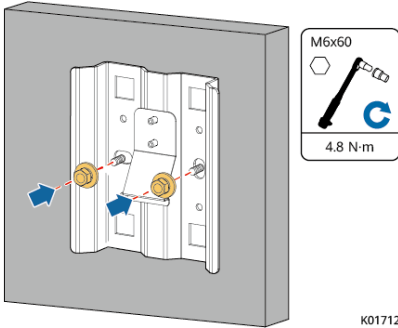

K01712

Securing with Rivets

- ① Mark mounting holes in an appropriate area on the wall.

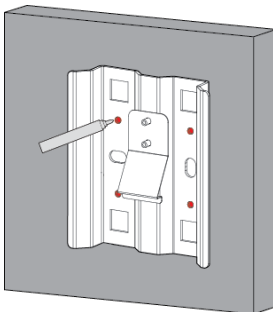

PC00H00114

- ② Drill holes in the marked positions.

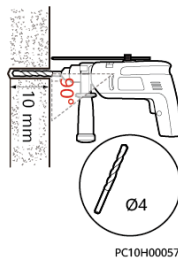

PC10H00057

- ③ Secure the base.

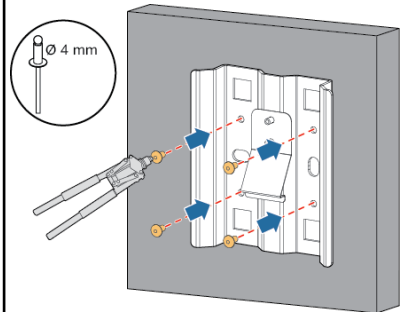

PC00H00039

Securing with Hose Clamps

- ① Secure the base to an appropriate position on the pole.

NOTE

Hose clamps support a pole with a diameter of 48–114 mm.

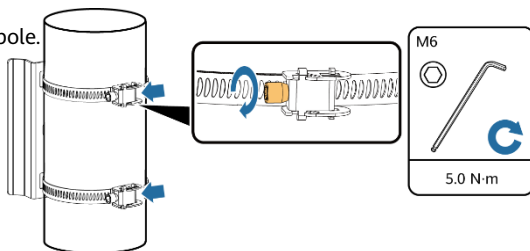

PC00H00094

2. Install an SJB.

Wall Mounting

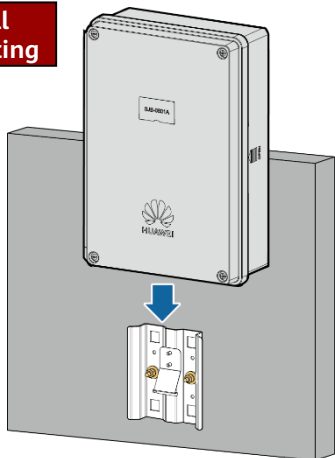

ZXJ0000234

Pole Mounting

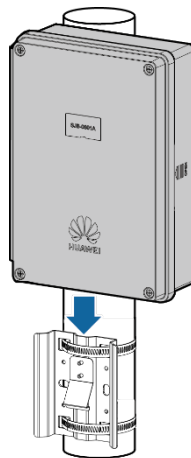

ZXJ0000235

3. Install an SJB ground cable.

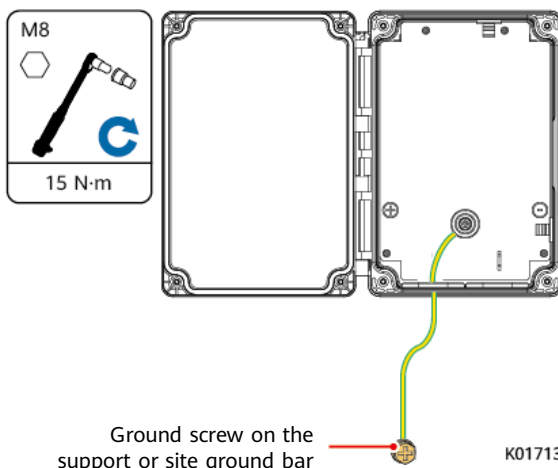

4. Install cables between PV modules and the SJB.

PV Module Type	Installation mode	Maximum Routes Connected to the SJB
540 W PV module	Every two PV modules are connected in series as one route.	4 (if configured with a 4 kW SSU)
		3 (if configured with a 3 kW SSU)

NOTE

The figure shows how to connect one route to the SJB.

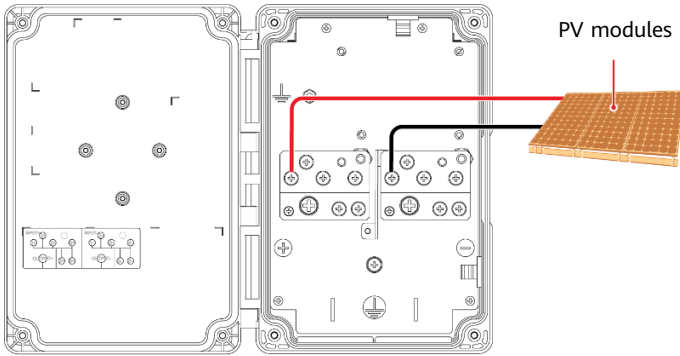

ZXJ0000266

3 (Optional) Installing a Signal Cable for Reporting PV Module Thefts

1. Route the cable through the holes on the rear of PV modules in sequence and bind the cable using cable ties.
2. Connect the cable to the DIN port on the user interface module (UIM). The following figure uses the DIN2 port as an example.

NOTICE

- If the signal cable is a two-core cable, select a color and ensure that the cables connected to the dry contacts are of the same color.
- If the cable is connected to a dry contact that reports an alarm when closed, set the dry contact to report an alarm when open.
- If the cable is connected to a multiplexing port and is an ALM output port, set it to a DIN port.

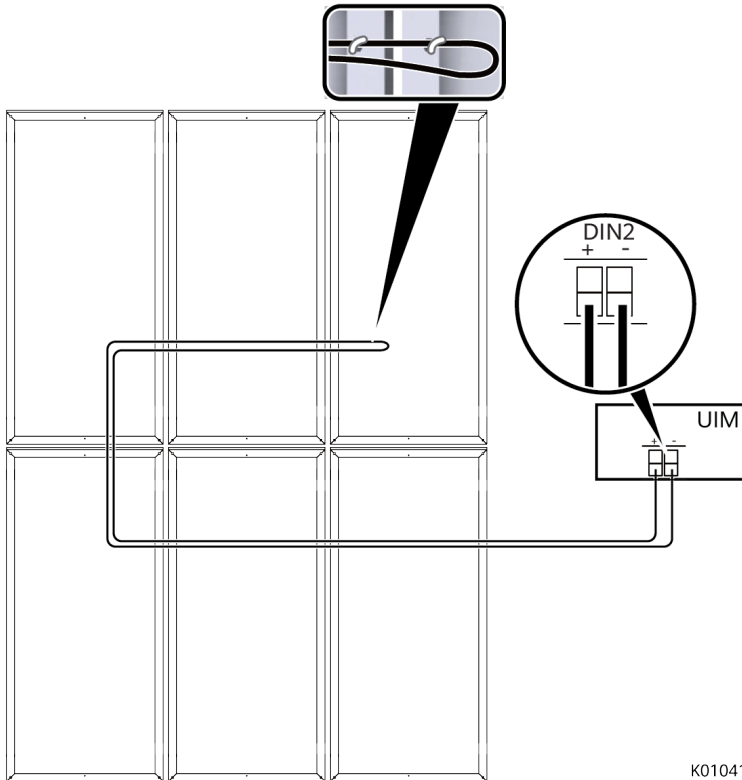

K01041

Huawei Technologies Co., Ltd.
Huawei Industrial Base, Bantian, Longgang
Shenzhen 518129 People's Republic of China
Postal code: 518129
www.huawei.com

BARBED WIRE FENCING AND GATE DRAWING

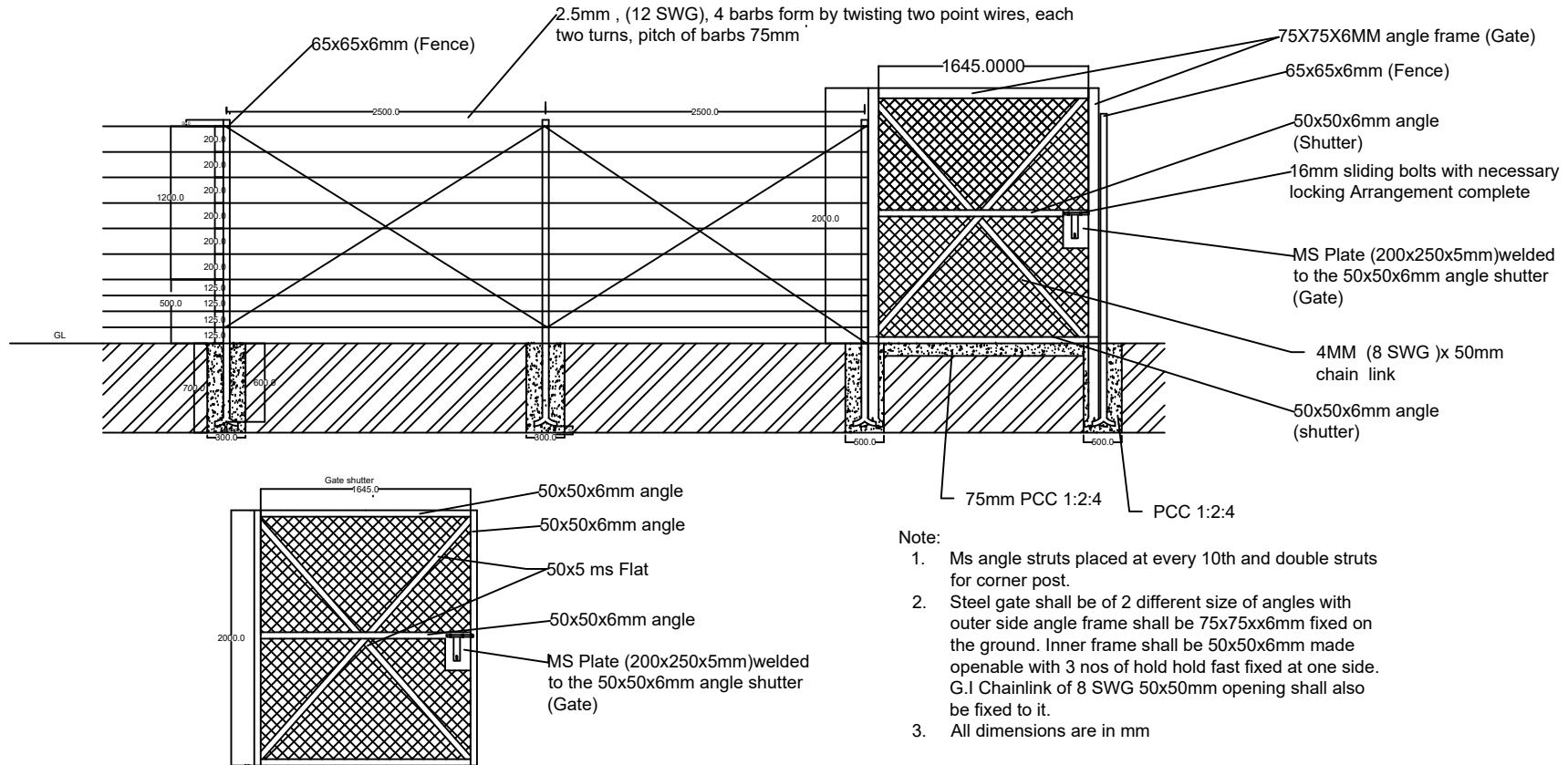

	Title : Barbed wire fencing	BHUTAN TELECOM LIMITED	
	Checked by:	Approved by:	